

XGT Panel Series is a brand new HMI product with an intensive and advanced technology of LSIS to cope with the rapidly changing market situation. It is an innovative product having both reliability and convenience based on the Windows CE. With the user-oriented convenience, it offers high resolution display, prompt data transmission and processing, and an user-friendly interface. LSIS provides the Leading Solution to the automation field with the XGT Panel Series. We are confident of our XGT Panel Series which contains high technology and our commitment to quality at the HMI market.

With the user-oriented convenience, it offers high resolution display, prompt data transmission and processing, and an user-friendly interface.

Human Machine Interface
XGT Panel
iXP Series / XP Series

**Leading Innovation,
Creating Tomorrow**



LSIS creates the core automation solutions for the fields ranging from production facilities to information systems.

It is the device and software operable using a designed screen for users to monitor and control the operating status of given facilities and equipments. Windows CE platform based XGT panel is a user-friendly solution, providing convenient, clear and realistic display, prompt data transmission and processing as well as easy environments.

Based on the advanced technologies, LSIS satisfies various requirements of clients, from unit facilities to advanced industrial fields, leading the HMI market.



C O N T E N T S

XGT Panel	04
XGT Panel iXP Series	06
Products Line Up	08
Feature	
Hardware Related Functions	10
XP-Builder	14
Software Related Functions	16
Advanced Functions	18
Link with Controllers	20
External Monitoring Function	22
System Block Diagram	24
Our Solution	26
Products	
iXP Series	28
XP Series	30
XP40	32
List of Communication Drivers	34

XGT
Panel



Data Logging

NO	DATE	TIME	POWER	SPEED	LEVEL
0	2007/03/30	17:37:12	2048	600	204
1	2007/03/30	17:37:17	4	1860	629
2	2007/03/30	17:37:22	1024	3100	1054
3	2007/03/30	17:37:27	2	4360	1479
4	2007/03/30	17:37:32	512	5600	1904
5	2007/03/30	17:37:37	1	6960	2329
6	2007/03/30	17:37:42	256	8100	2754
7	2007/03/30	17:37:47	0	9260	3179
8	2007/03/30	17:37:52	128	10200	3604
9	2007/03/30	17:37:57	-32768	11860	4029
10	2007/03/30	17:38:02	64	13100	4454
11	2007/03/30	17:38:07	16384	14360	4879
12	2007/03/30	17:38:12	32	15600	5304
13	2007/03/30	17:38:17	8192	16860	5729



XGT Panel

neXt Generation Technology

We are in the forefront with advanced technologies for clients.

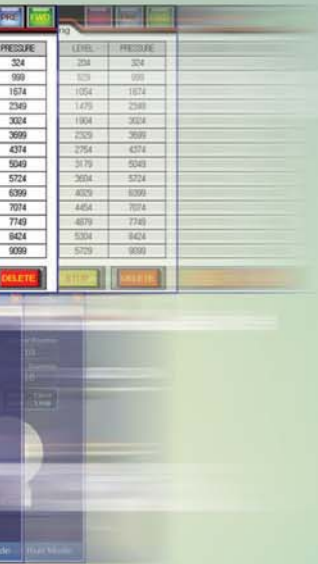

XGT Panel is a brand new HMI product with an intensive and advanced technology of LSIS to cope with the rapidly changing market. It is an innovative product having both reliability and convenience based on Window CE Platform. With the user-oriented convenience, it offers high-resolution, realistic display, prompt data transmission and processing and user-friendly interface. LSIS, offering a Leading Solution in the automation field, proudly presents the XGT Panel series at the HMI market with the advanced technologies and product quality, following the XGT PLC.

Excellent Performance & Convenient Functions

- ☑ Clear and high-resolution display with 16.7M TFT and 65K TFT colors
- ☑ Various vector symbols and high quality raster symbols
- ☑ Supports a wide range of graphic formats including BMP, JPG, GIF, WMF
- ☑ Simple video clips with GIF drawing
- ☑ 10/100 BASE-T Ethernet interface as a default
- ☑ Convenient and easy screen editing
- ☑ Enhanced data management function (Logging, Recipe and Alarm)
- ☑ Read function of the controller's status information (diagnosis, monitoring and maintenance)
- ☑ Multi-lingual display of up to 8 languages and a batch language changing function
- ☑ Offline simulation program (link with the XG5000 simulator)
- ☑ HMI S/W tag function (easy to change the device address mapped to graphic objects)
- ☑ USB Host/Device function for using various PC devices (mouse, keyboard, and etc.)
- ☑ Sufficient memory space for project
- ☑ Excellent performance and convenient functions

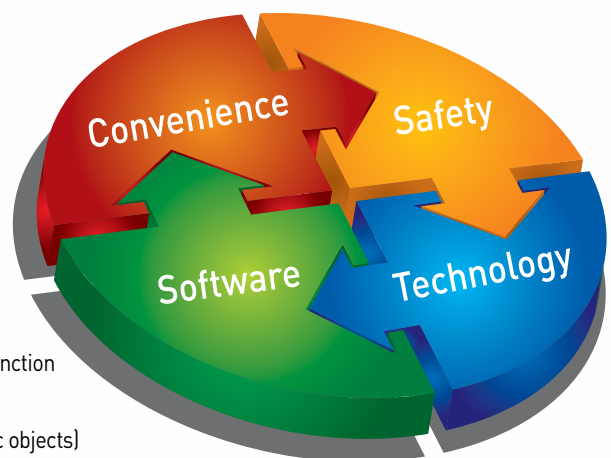



XGT

Panel



NEW
Product

XGT Panel

iXP Series

Convenient control with a single touch!

A user-oriented interface, enhanced performance, and soft and quick screen switching and respond speed to touch!

Meet iXP series of LSIS that genuinely and fully connects humans with equipments.



It is highly competitive using the user-friendly technologies.

- ☑ Quick screen switching and response speed to touch
- ☑ 16.7M TFT colored LCD
- ☑ Large drawing / backup memory (Drawing-128MB, Backup-1MB)
- ☑ Sound I/O support
- ☑ Various interfaces
 - USB Host 3ch (Front: 1, Rear: 2), Device 1ch (Front)
 - SD card
 - Various communication drivers provided
- ☑ Presence sensor applied (within 1m)

High Speed

High-performance 1GHz CPU is installed to improve the data and screen switching speed, and Windows CE 6.0 Professional OS is adopted to execute NET-based external applications.

Large Memory

Large device memory is provided to save mass data.

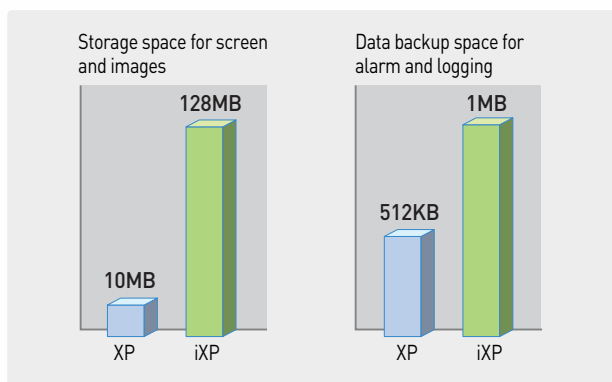

Presence Sensor

Sensor detects movement within 1m, to control the backlight, ensuring a longer life of the product.

More Colorful

High luminance/resolution LCD with an LED backlight and 24 bit colors to express clear and vivid colors of 16,777,216.





Products Line-up

Window CE-based new HMI developed with advanced technologies of LSIS to optimize the user experience

XGT Panel iXP / XP Series

		15" (38cm)	12.1" (31cm)	10.4" (26cm)
iXP Series	Standard	<p>iXP90-TTA</p>  <p>TFT 16,777,216 colors XGA(1024 × 768 dots)</p>	<p>iXP80-TTA</p>  <p>TFT 16,777,216 colors SVGA(800 × 600 dots)</p>	<p>iXP70-TTA</p>  <p>TFT 16,777,216 colors SVGA(800 × 600 dots)</p>
	<p>Standard</p> 			
XP Series	General	<p>XP90-TTA</p>  <p>TFT 65,536 colors XGA(1024 × 768 dots)</p>	<p>XP80-TTA</p>  <p>TFT 65,536 colors SVGA(800 × 600 dots)</p>	<p>XP70-TTA</p>  <p>TFT 65,536 colors VGA(640 × 480 dots)</p>
	<p>General</p> 			
	Economical	<p>Economical</p> 		



8.4"(21cm)

iXP50-TTA



TFT 16,777,216 colors
SVGA(800 × 600 dots)

8.4"(21cm)

7"(17.7cm)

5.7"(14cm)

XP50-TTA



TFT 65,536 colors
VGA(640 × 480 dots)

XP40-TTA



TFT 65,536 colors
WVGA(800 × 480 dots)
※ CF card I/F and expansion
ports not supported.

XP30-TTA



TFT 65,536 colors
QVGA(320 × 240 dots)

XP30-BTA



STN MONO (8-column Gray)
QVGA(320 × 240 dots)

XP40-TTE



TFT 65,536/256(Default) colors
WVGA(800 × 480 dots)
※ CF Card I/F not supported.

XP30-TTE



TFT 256 colors
QVGA(320 × 240 dots)

XP30-BTE



STN MONO Economical type
(8-column Gray)
QVGA(320 × 240 dots)
※ CF Card I/F and USB I/F
not supported.

Hardware Related Functions **iXP**

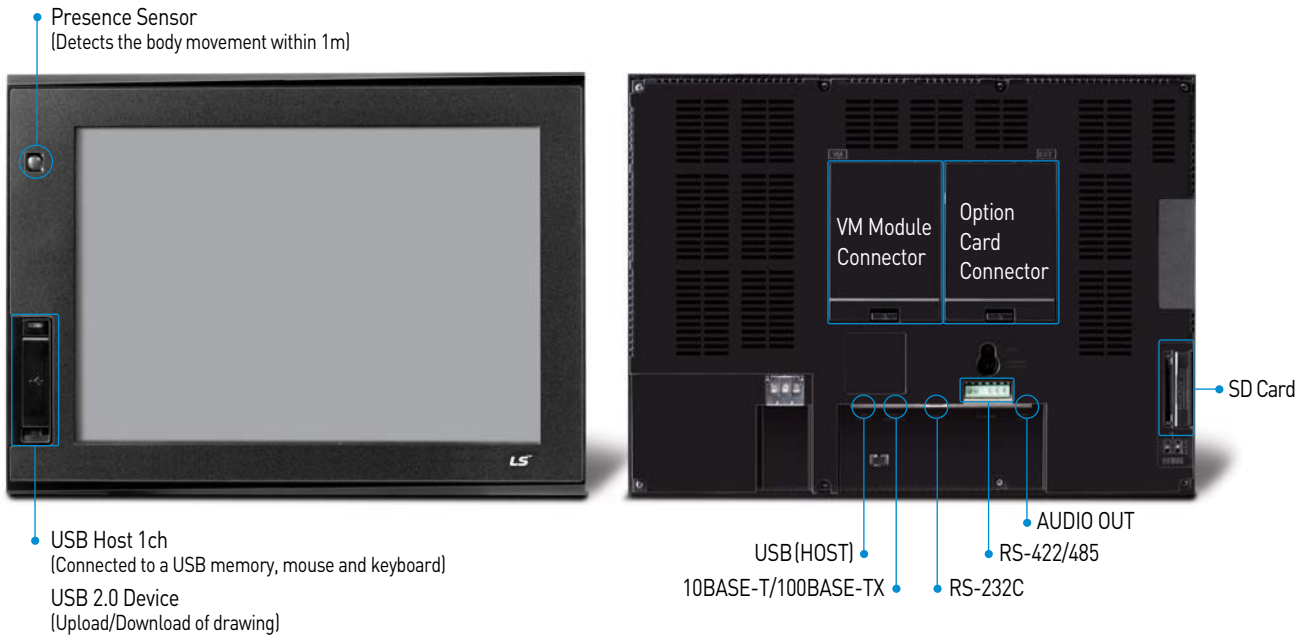

iXP 1 Respective Front USB Host/Device Channel

- An additional USB host channel is installed in the front panel.
- A front USB host is used to connect to a USB memory, mouse and keyboard.
- A front USB device port is used to change the XP-Runtime without opening a control panel or download/upload the drawing file created using XP-Builder.
- USB download cable (USB-310A)



iXP Sound Output Function (For all iXP models)

- The sound files (wav, mp3) registered using XP-Builder can be output to speakers connected to HMI.
- An alarm is generated via speakers to warn operators.
- Up to 512 sound files can be saved.



iXP Function to use SD Cards

iXP supports additional SD memory cards along with previous USB memory to diversify the backup means.

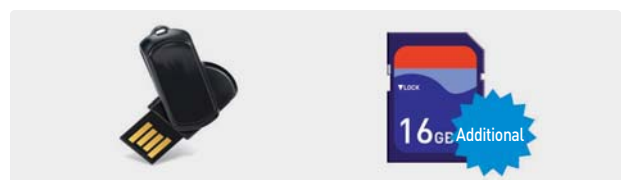

iXP Presence Sensor (For all iXP models)

- The XP presence sensor detects movement within 1m to turn on a backlight.
- When not used, it turns OFF the screen to maintain a longer lifespan of the backlight.

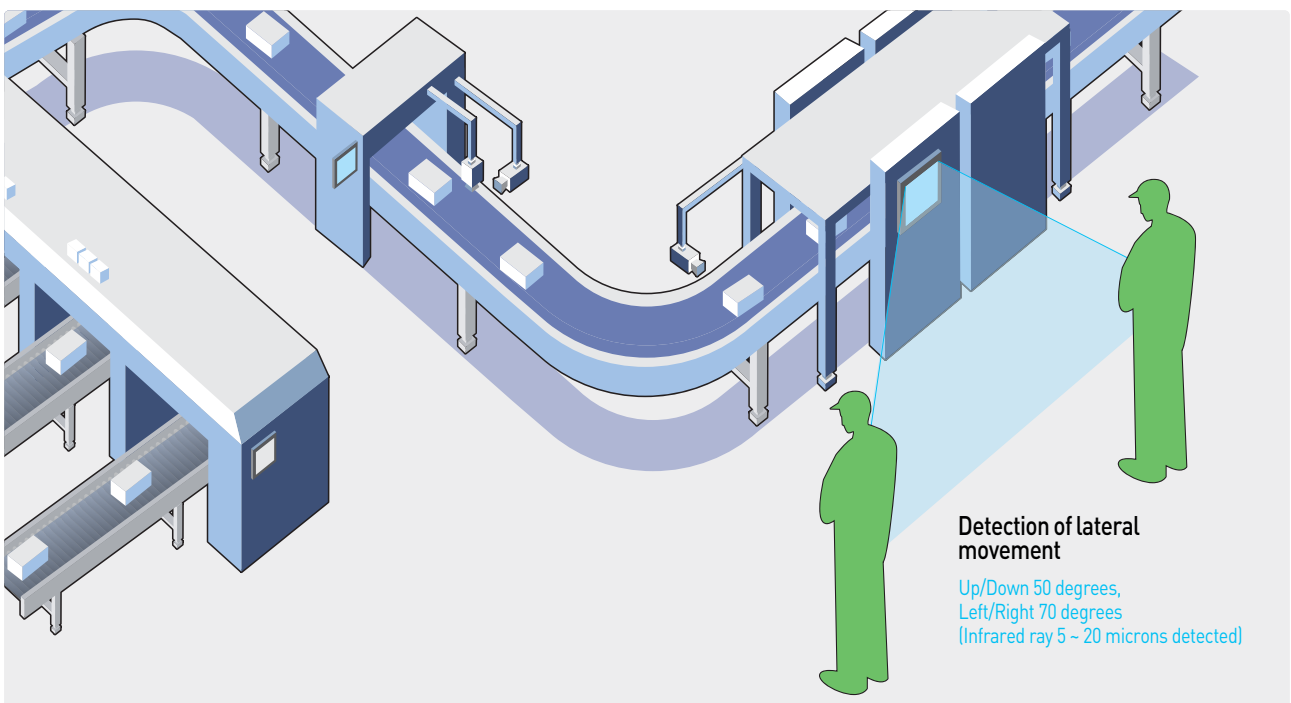
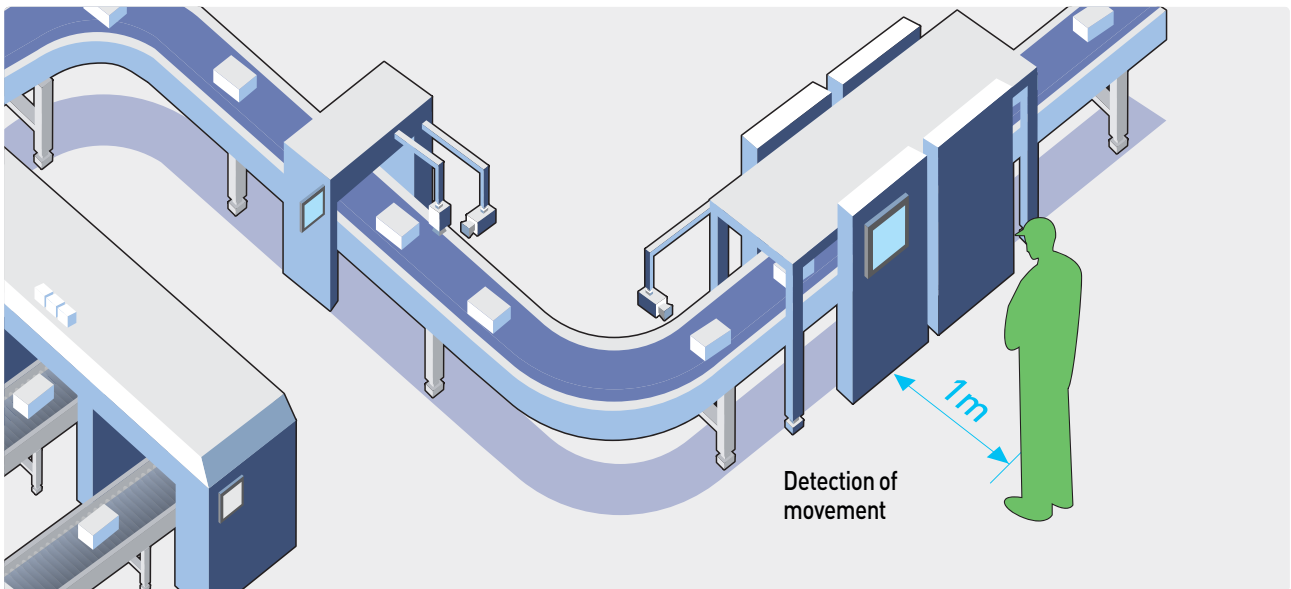

Hardware Related Functions **XP**



USB Host
CF card: effective use of USB memory



RS-422/485
RS-232C
Ethernet

XP USB Host

- 2 USB interface channels
- Various access devices can be used using the USB I/F.
- Access to mouse, keyboard, a USB external hard disk, barcode reader and USB hub is possible, Access to mouse, keyboard, a USB external hard disk, barcode reader and USB hub is possible. Continuous upgrades and developments to cope with other drivers are under progress.

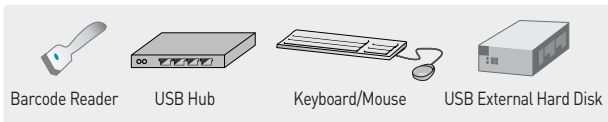

XP A type **USB Cable (XP0-USBC)**

- USB cable is used for screen data transmission and XP-Runtime updates.
- The versions before XP-Builder 1.30 are not installed with the USB driver, thus it must be installed.



XP Effective Use of USB Memory

- PLC data can be saved in a CF card or USB memory. If necessary, they are converted into a CSV format to be used to prepare daily and monthly reports.
- When the drawing files using XP-Builder are saved in a CF card or a USB memory and copied to the XGT Panel, they can be executed without being sent via cables.
- When there are several XGT Panels, one CF card or USB memory can be used to copy each XGT panel, allowing a setup.
- A CF card or a USB memory can be used for engine updates and upload/download of drawing files.

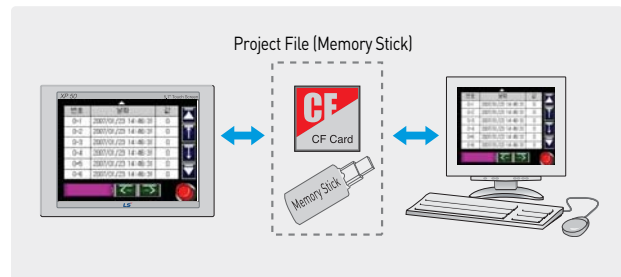

Hardware Related Functions **iXP** **XP**

iXP **XP** Ethernet method for Quick Transmission of Mass Data

- Ethernet method has improved the transmission speed. Compared to the conventional RS-232C method, a quicker transmission speed: 115kbps → 10/100Mbps
- Regardless of the memory capacity, the drawing files can be quickly uploaded/ downloaded, and logging/alarm/recipe data can be conveniently used.
- Ethernet method is used for various production data collection, monitoring and control using PC.

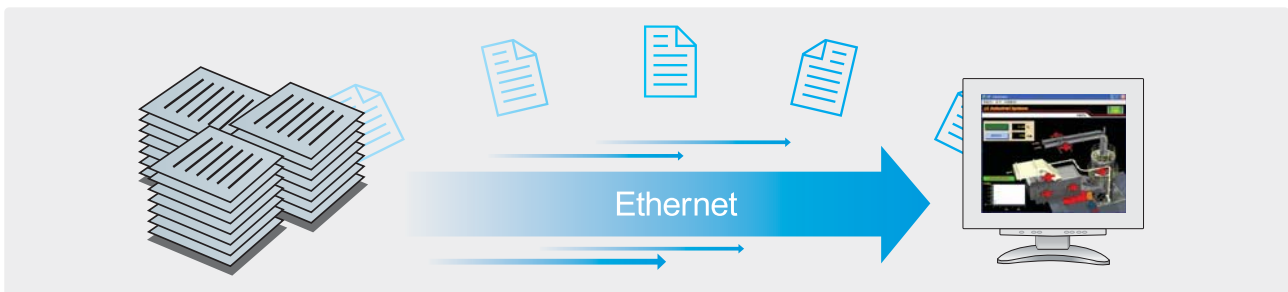

iXP **XP** Barcode Scanner Communication

- ASCII data imported by accessing a barcode scanner from XGT Panel can be saved in the user-assigned PLC or XGT Panel's internal memory.
- Complete Bit can be randomly saved. It allows users to check whether the XGT Panel has read the data without errors.
- Communication with barcodes is possible by using the RS-232C interface installed in the XGT Panel.

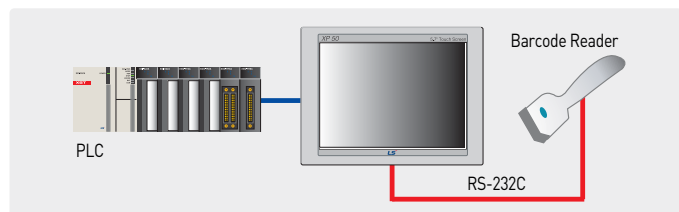

iXP **XP** Providing Various Communication Channels

Using RS-232C, RS-442/485 and Ethernet, XP and iXP are capable of communicating with up to 4 and 6 types of controllers, respectively. Refer to the system block diagram Page 31 (XP30 economical type does not have an Ethernet module).

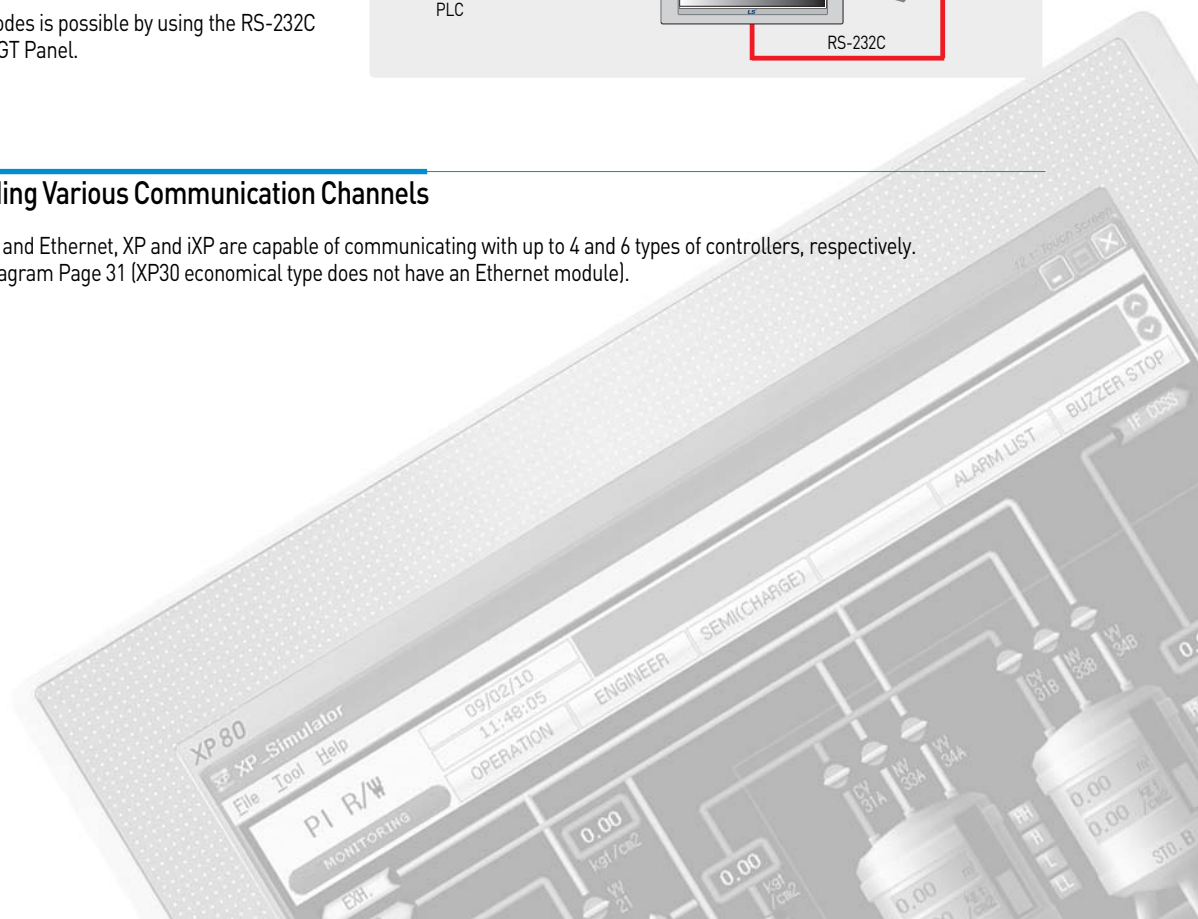

XP-Builder

XGT Panel offers easy and user-friendly multi-interface.

XP-Builder Functions

Implementation of multiple programs

In order to use the previously created drawing data for a new drawing, more than 2 XP-Builder programs are executed simultaneously.

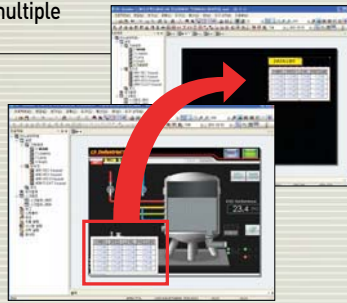

Function to check data

- To check for any error on the data created, and errors can be corrected by clicking on them.
- The specific description of error created is displayed.



Cross-reference function of devices

Devices used for drawing data and tags are displayed.

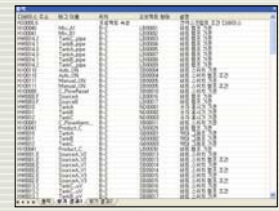

Drawing Editor: XP-Builder

Project Window

Aligned for easier addition and edition of project view screens and special functions.

Data Element Window

- Displays the objects on a screen currently shown.
- When double-clicked, a window on setting the properties appears.

Output Window

- Displays the error checked on drawing data and the search results.
- It displays the specific description of the errors created.

Tool Box

Used to select an object or draw a shape.

Library Window

- Library is divided by category for easier use, and preview is used for drawing.
- Convenient for users to register and delete the Library.
- Drag & Drop is used for a screen insertion.

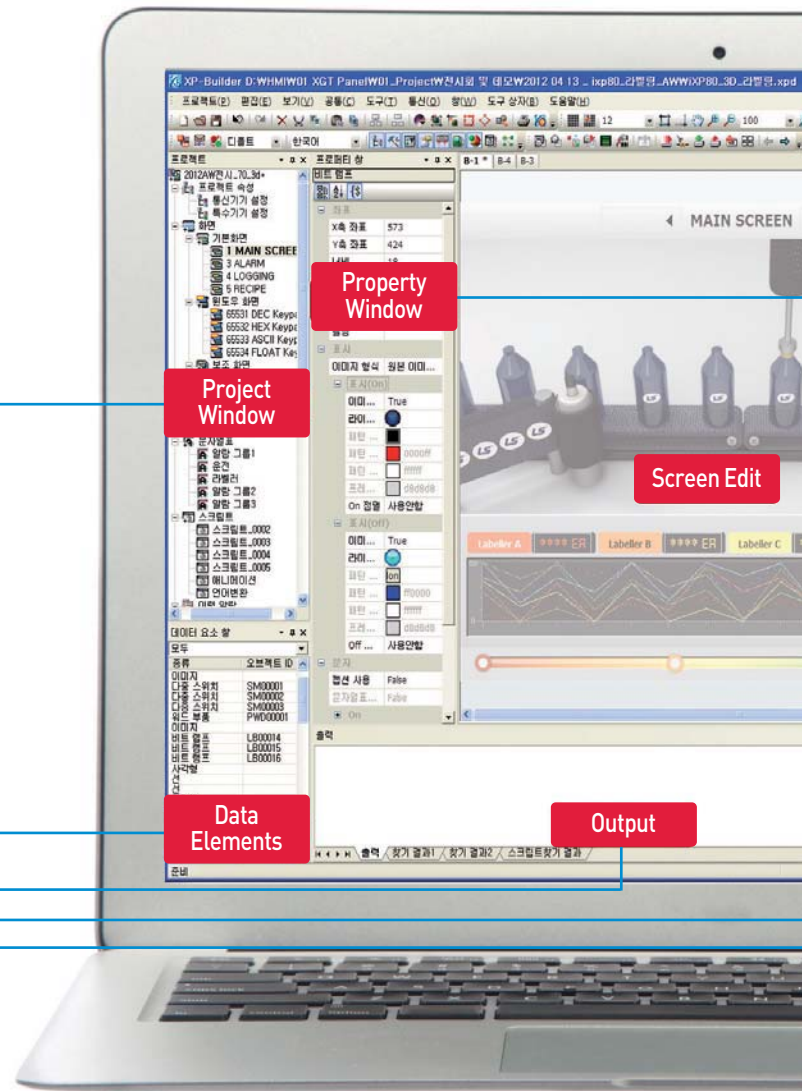

Tag function

- Users can set device address by desired name, which can be used in an object.
- When a set device is tagged to an object, addresses can be changed, collectively
- Up to 10,000 tags can be registered.

이름	타입	장치 주소	주소	비고
SourceA	BIT	HW000.F		
SourceA_V1	BIT	HW000.F		
SourceA_V2	BIT	HW000.E		
SourceA_V3	BIT	HW000.E		
SourceB_V1	BIT	HW000.E		
SourceB_V2	BIT	HW000.E		
SourceB_V3	BIT	HW000.E		

Various fonts with convenient setting options

- Windows fonts used in a PC can be transmitted to HMI for use.
- When using Windows fonts, font attributes (Italic, bold and underline) can be used as well.
- Various font sizes including True Type are supported.
- Supports the Unicode, characters of other countries such as the standard font and high-quality fonts are beautifully displayed.
- Sophisticated and elegant text can be used to create a screen using various fonts.

Arial : ABCDEFGHIJKLMNOPQRSTUVWXYZ
 Book : ABCDEFGHIJKLMNOPQRSTUVWXYZ
 Impact : ABCDEFGHIJKLMNOPQRSTUVWXYZ
 Helvetica : ABCDEFGHIJKLMNOPQRSTUVWXYZ
 Tahoma : ABCDEFGHIJKLMNOPQRSTUVWXYZ
 Time : ABCDEFGHIJKLMNOPQRSTUVWXYZ
 Verdana : ABCDEFGHIJKLMNOPQRSTUVWXYZ

가나다라마바사아자차카타파하
 가나다라마바사아자차카타파하
 가나다라마바사아자차카타파하
 가나다라마바사아자차카타파하

Animation function

- When GIF format is used, animation effects can be realized depending on the state of given bit.
- When a video clip on given site is created into GIF to be added to a drawing screen, more accurate information can be delivered to users. (Video clip files can be created using the commercial software for GIF creation)



User-oriented screen UI

Providing a flexible script language

- Provides a screen UI that can be easily used considering user's experiences.
- Divided into categories so that a graphic library can be easily searched.
- Various graphic libraries are offered for enhanced usability.

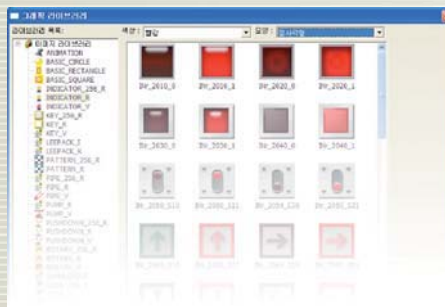

Property Window

- This function enables users to change properties of numerous objects at once, so that users do not have to open each object like a button or a lamp for modification.
- Numerous objects on the screen can be selected at once to replace the pictures, enhancing users' convenience.
 - When modifying several objects, only the objects with the same function should be selected.
 - Users can correct both pictures and properties.

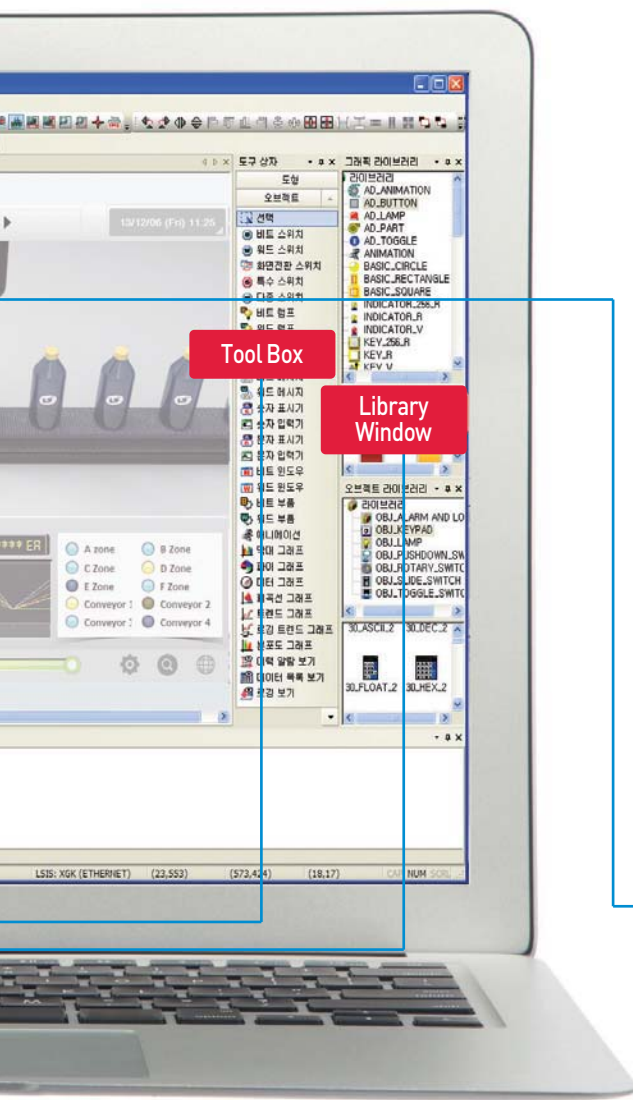

Software Related Functions

Multi-lingual support & conversion to respond to the global enterprise environments

- In response to enterprise environment of global era, up to 8 languages can be simultaneously converted and users can select a language depending on his/her nationality.
- When desired character string is registered in a table, a language can be converted into a device value and switched upon operation.
- The languages supported include Korean, English, Chinese (PRC/Taiwan), Japanese, French, Turkish, Iranian (Persian), German, Greek, Russian, Italian, Norwegian, Polish, Portuguese and Spanish, all of which are supported in Windows.

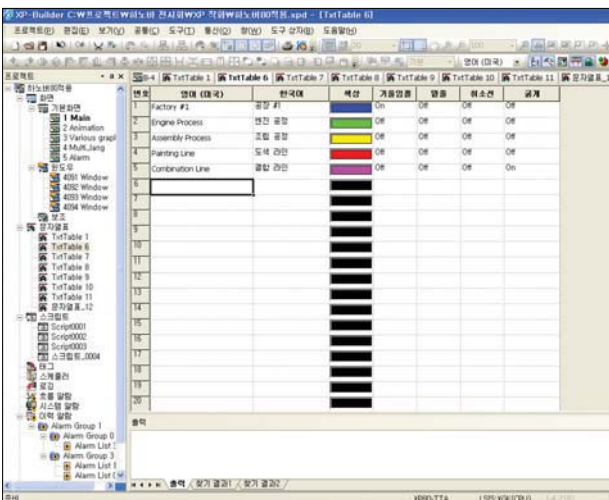

Strict control management using security setting

- Upon PLC control using objects like a switch or an input method editor, only the authorized users can perform controls depending on the set security level.
- It supports 10 security levels in total, and the password of a sub-level can be accessed using the password of a main level.
- When the security level is authorized, a session is disconnected after a certain period of time, asking for the password again.

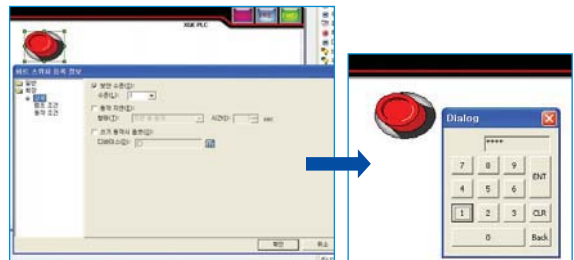

Free and easy moving of parts

- The fixed values and the parts related to the word device are selected/switched to be displayed on a screen, and the images registered as the given parts can be used.
- A mouse is used to set the movement points for free moves, linear moves, and device moves based on the X and Y coordinates, which can be chosen by users.

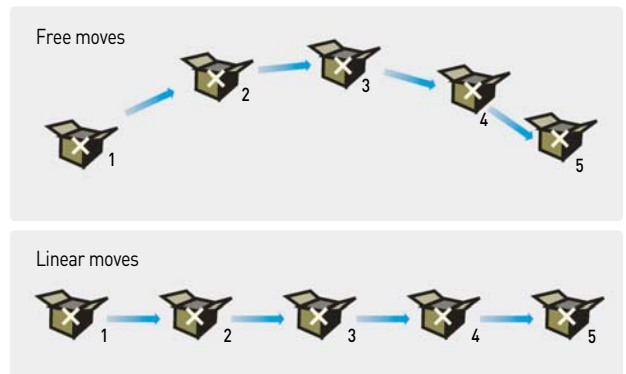

Automatic registration of a character string table

This function enables the character string input by users in the objects to be automatically registered.

- When the file created using a single language is to be changed to a character string table for the purpose of multi-lingual support, it can be automatically registered to the character string table without inconvenience of users.
- All the static strings used in objects can be registered in the character string table.
- Up to 10,000 character strings can be added to a character string table, and the name of a new character string table and the editing languages can be set and registered by users.

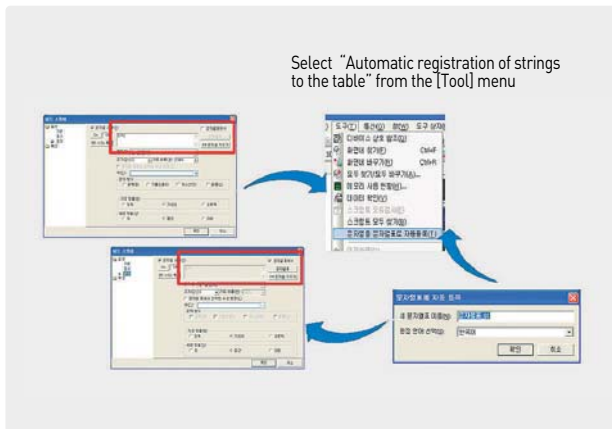

Memo pad function

Function to create or save a short message by selecting various pen thicknesses and colors on XGT Panel.

- It is useful in exchanging messages between operators working in turns.
- The user chooses the thickness and color of the pen and writes on a screen in order to input the message.
- Such memo can be saved in a CF card or a USB memory, and the data are archived even when the power is turned off.
- Users touch the screen and drag to create a memo.
- When creating a memo, users can UNDO/REDO the memo, the thickness/color of a pen can be changed, and a specific memo or all memos can be deleted.

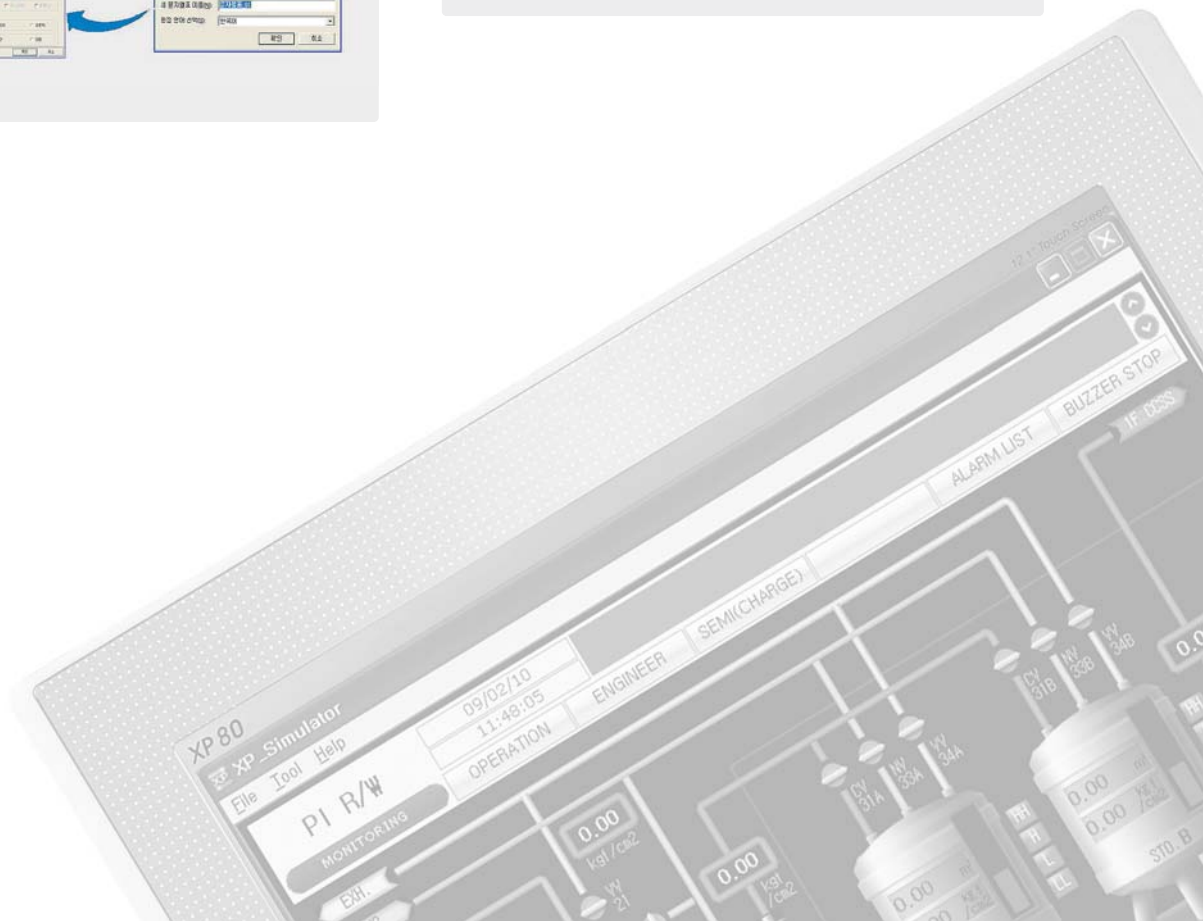
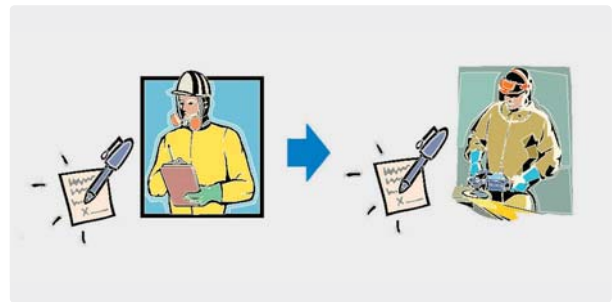

Advanced Functions

Alarm Function

- History Alarm**
 The history of alarms can be saved in the device to check the description of occurrence.
 The alarm can be categorized into up to 8 upper and 8 lower class groups or an alarm list, and an alarm explorer can display only the group alarms the user may desire. When a screen on description to check the details of alarms generated is registered, the detailed screen window linked to the alarm will appear.
 (It can be used to check the measures or detailed description when an alarm is generated.)
- Flow Alarm**
 The alarm generated is displayed on the upper/mid/lower section for users to promptly take actions.
 Flow alarm can be set to be operable at a specific screen, so it can be used to deliver the information on equipments and company.
- System Alarm**
 When a serious fault or a trouble of HMI occurs, the system alarm informs the users, which is a critical function.

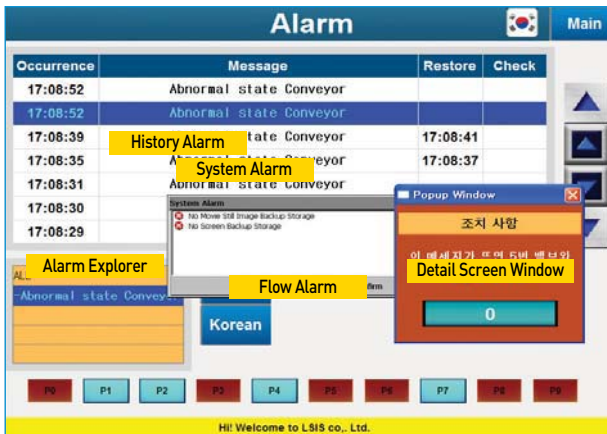

E-mail Function

- It offers a function to send backup files (.csv) using the E-mail address registered upon backup of the logging and alarm data in XGT Panel.
- The E-mail function for logging can only send the backup files of the group desired for each logging group.
- The E-mail function for history alarm includes a function to send to the E-mail only on the alarm messages to the designated receivers when the user-assigned alarm is generated or recovered.
- The logging and alarm backup files sent can be easily analyzed in PC using a program like EXCEL.

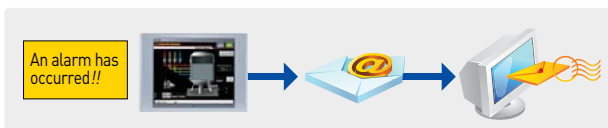

Logging Function

- It offers a cyclic logging that is repeated depending on the time and device state and a conditional logging which works under the device conditions.
- Up to 32 logging areas (conditions) can be provided, and the maximum size of an area can be set up to 256Kbyte.
- Up to 100 words (64Bit upon bit logging) per logging can be saved.
- Basically, logging is saved in the built-in SRAM(256Kbyte), and the backup of logging is available using the CF card, USB memory stick or USB external hard disk.
- Logging data can be viewed in XGT Panel using a logging view object, and they can be converted into a CSV format to be easily edited using a PC via software such as EXCEL.

시작	종료	POWER	SPEED	LEVEL	PRESSURE
0	2007/03/30 17:37:12	2048	660	254	124
1	2007/03/30 17:37:17	4	1950	629	399
2	2007/03/30 17:37:22	1024	3100	1054	1674
3	2007/03/30 17:37:27	2	4990	1479	2349
4	2007/03/30 17:37:32	592	5600	1904	3024
5	2007/03/30 17:37:37	1	6690	2329	3699
6	2007/03/30 17:37:42	256	8100	2754	4374
7	2007/03/30 17:37:47	0	9050	3179	5049
8	2007/03/30 17:37:52	128	10600	3604	5724
9	2007/03/30 17:37:57	-32768	11950	4029	6399
10	2007/03/30 17:38:02	64	13100	4454	7074
11	2007/03/30 17:38:07	16384	14200	4879	7749
12	2007/03/30 17:38:12	32	15600	5304	8424
13	2007/03/30 17:38:17	8192	16890	5729	9099

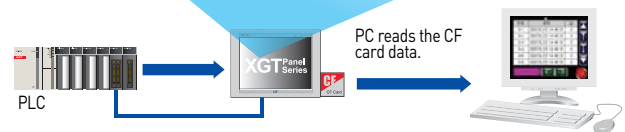

Encryption of Logging/Alarm Backup Files

- The backup file format can be archived as binary files to prevent the data from being damaged or manipulated.
- The encrypted files can be converted into CSV files using a CSV file converter offered from XP-Builder.

Scheduler

- Scheduler assigns an operation to be executed on a set time.
- Available functions include Bit ON/OFF, setting Word values and a script operation. Each scheduler can assign up to 8 operations.
- Up to 32 schedulers can be set.



Recipe

- After the data to be written on PLC are created, the data values created on a PLC device continuously connected to a specific device can be written.
- It can read a lot of device values from the PLC continuously connected to a specific device.
- XP-Builder can register up to 32 recipe items. Each recipe can register up to 10000 Word/D Word devices and 255 table blocks.
- Recipe data are saved in a non-volatile memory of XGT Panel. Thus, when the power is out, the data saved at the last minute are kept.
- Recipe data can be registered and edited using a XGT Panel or an EXCEL program.

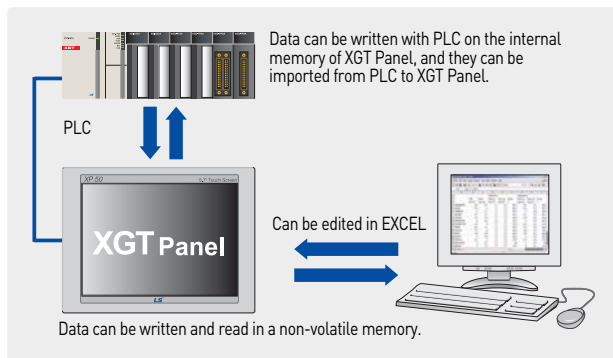

Script

Providing a flexible script language

- It is difficult to perform drawing using only the provided object functions, and it can be supplemented using a script.
- A structured language similar to the C language is used for user's convenience.
- The script using complicated arithmetic operations and various functions is executed to greatly reduce the load upon external controllers.
- A validity check of the grammar on the created scripts is available.

Various uses of scripts

- A wide range of scripts including global scripts, screen scripts and object scripts can be used depending on the usage.
- A global script operates according to ON/OFF of the device assigned, regardless of the screen operation, and a special device can be used for scripts in a regular basis.
- An object script can perform operational management of the object devices.
- A script can run when a screen opens or closes.

Convenient script tool box & script error check

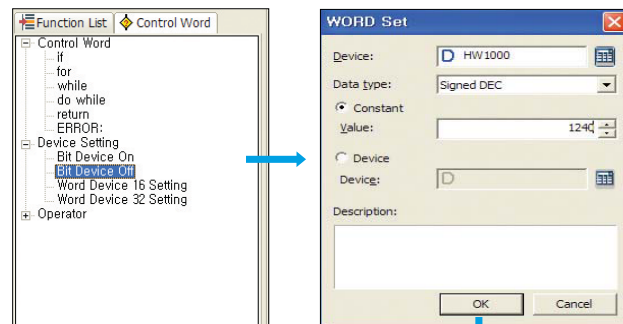

```

1 // Copyright (c) 2004~2006
2 // All rights reserved.
3 // Visit us: http://www.lsis.biz
4
5
6 if(@[W:HW1000] == 1240)
7 {
8     @[W:HW4000] = 5;
9     @[X:Hx0000] = false;
10 }
11 else
12 {
13     @[X:Hx00037] = false;
14     @[X:Hx00020] = true;
15 }
16
17 ERROR:
18 {
19 }
20
21
    
```



Link with Controllers

Convenient Simulator

Offline simulation

- Without XGT Panel, the drawing data can be directly viewed from PC.
- Devices can be monitored using a PC, and values can be directly input to check operations.
- A simulator is used to check the operations just like the XGT Panel. Before transmitting the drawing data to HMI, data errors and abnormal operations can be checked.



Link with the PLC Simulator

- When XG5000 simulator runs in a PC, users can control and monitor PLC directly by linking with PLC simulator.
- Operational data values of XG5000 simulator are reflected in the XP-Builder simulator, and when the values are input at XP-Builder, they are reflected as the operational data values in XG5000 simulator.

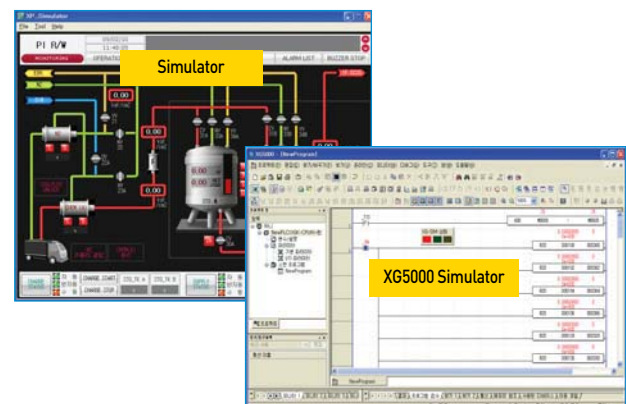

Path-through

When XGT Panel is connected to PLC with CPU serial port, PLC ladder program can be modified using the internal Ethernet.

- It is available only when the communication between the XGT Panel and the PLC is a CPU serial connection (Cnet module is also possible for the LSIS PLC).
- Users no longer have to change the cable for PLC program modification, or to go to the PLC for changes.
- A program can be modified even when a control panel is far away.

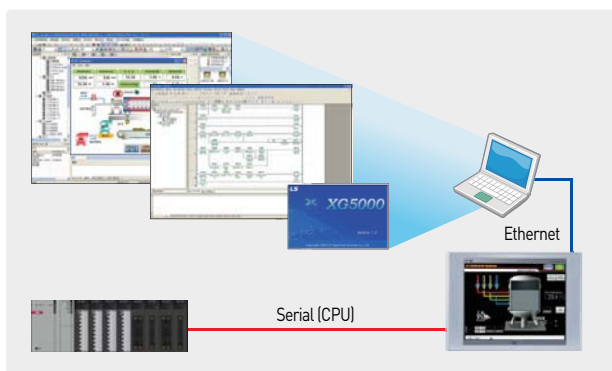

Note) Used when the communication between the XGT Panel and the PLC is the CPU serial communication

Using XGT PLC for batch-registration of devices (tag function)

The variable names used in the PLC program that is created using XG5000 are automatically registered in XP-Builder, so that they can be used in drawings.

- [Save as a Variable/Description File] of XG5000 is used to first save the variable names used as CSV files.
- Using [Import XG5000 Symbols] from the [Tag] item of XP-Builder, an automatic registration via tags is possible (Array variables supported).
- Without changing the memory address, the variables used in the PLC program can be used.

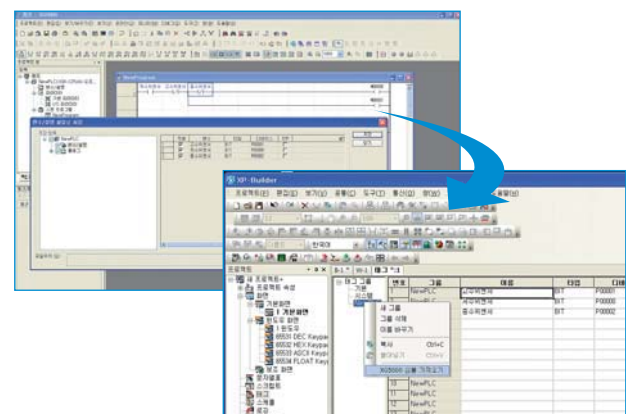

Communication Options

Fieldbus option provided

Various Fieldbus communications using the XGT Panel options

(RAPIenet, Profibus-DP and CANopen Slave offered)

RAPIenet(XPO-EIMT) optic ring system diagram

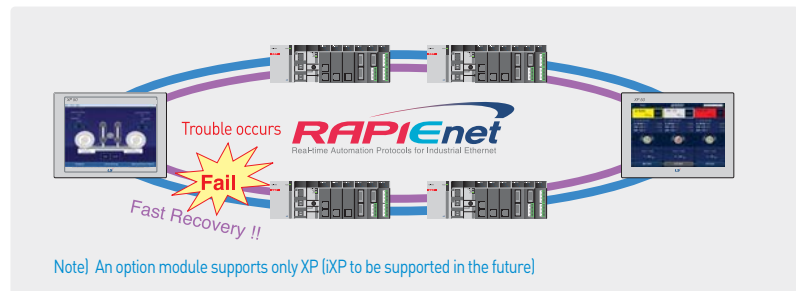

XP-Server Function

The data required from the production site's XGT Panel can be directly collected or saved in a PC. It has several roles including a mutual data exchange between several XGT Panels, or sending an E-mail or connecting to a Database.

- It connects to the Database via PC to save, inquire and manage the XGT Panel data.
- When a trigger condition is generated, users will be informed via data E-mail of PC.
- When a trigger condition is generated, it imports or writes the screen capture, logging, alarm and recipe data of a specific XGT Panel.
- It is possible to collect various information including production outputs and causes of errors and failures from the XGT Panel to the DB server

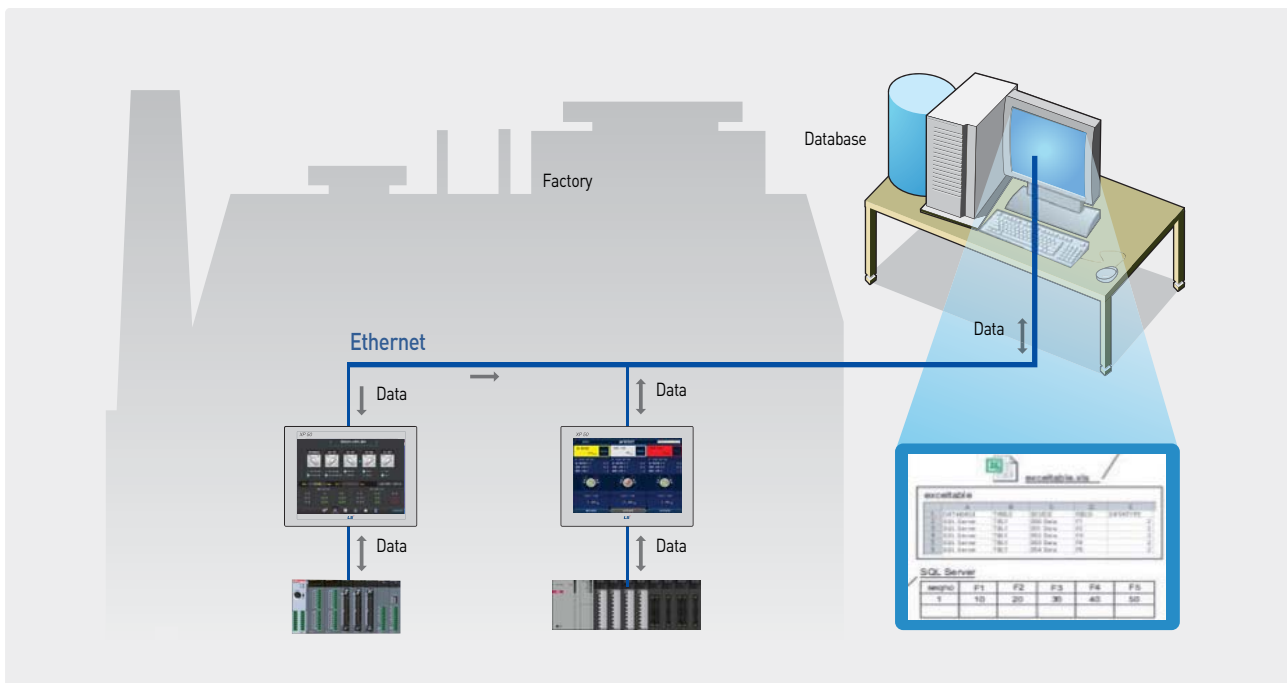

External Monitoring Function

※ Only the Ethernet-support models can use the function.

XP-Remote

- An XGT Panel screen can be monitored and controlled remotely with a PC.
- Up to 4 PCs can remote-access to a single XGT Panel. (Only one PC can access XP-VNC.)
- Remote PC control of XGT Panels can be authorized or restricted (When not authorized, it is impossible to control with the Remote PC).
- There is a synchronization mode and a non-synchronization mode, which allows users to monitor the XGT Panel and the Remote PC screen under the same or different conditions.

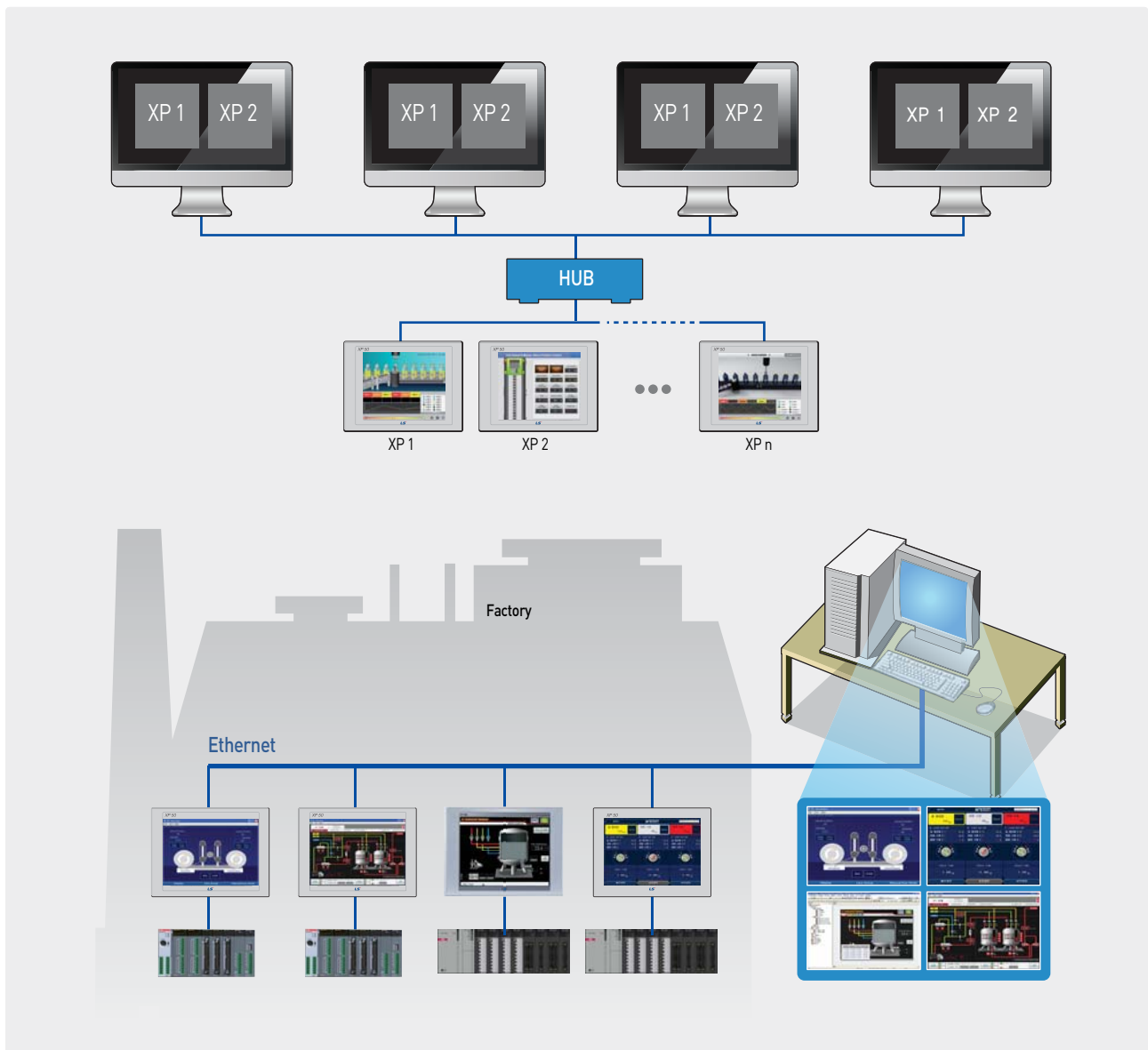

Web Server

- The screen currently viewed on a XGT Panel can be viewed on a web browser via Internet.
- It is accessible in any place where Internet is connected.
- It can be connected to multiple Internet Explorers. (Impossible to access the XP screen at the same time)
- It is possible to upload the logging and alarm backup files as csv files in the XGT Panel.
- It is possible to restrict access of specific users or groups.

※ The functions described above are available when a Web Server Program is installed to the XGT Panel using XP-Manager.

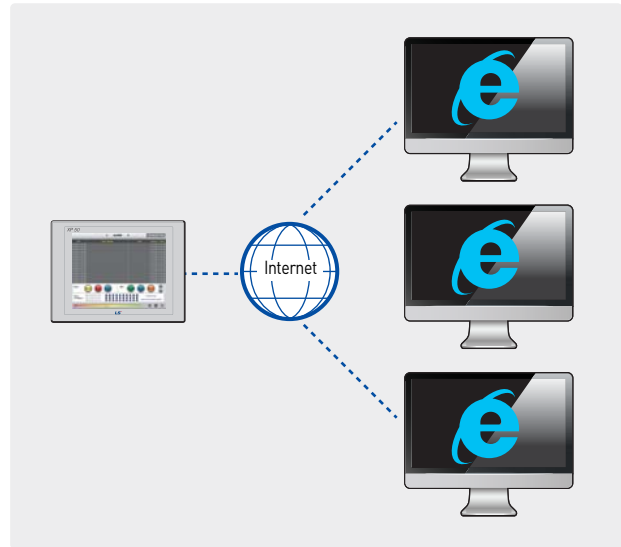

XP-VNC

- The screen currently shown in the XGT Panel can be viewed from the user's PC.
- Several XGT Panels can be monitored and controlled with one PC.
- After inserting the IP of XGT Panel to be accessed from XP-VNC (S/W for PC), the current screen of the XGT Panel can be monitored and controlled.
- It is possible to restrict PC control when the XGT Panel is under operation on site (VNC interlock device provided).

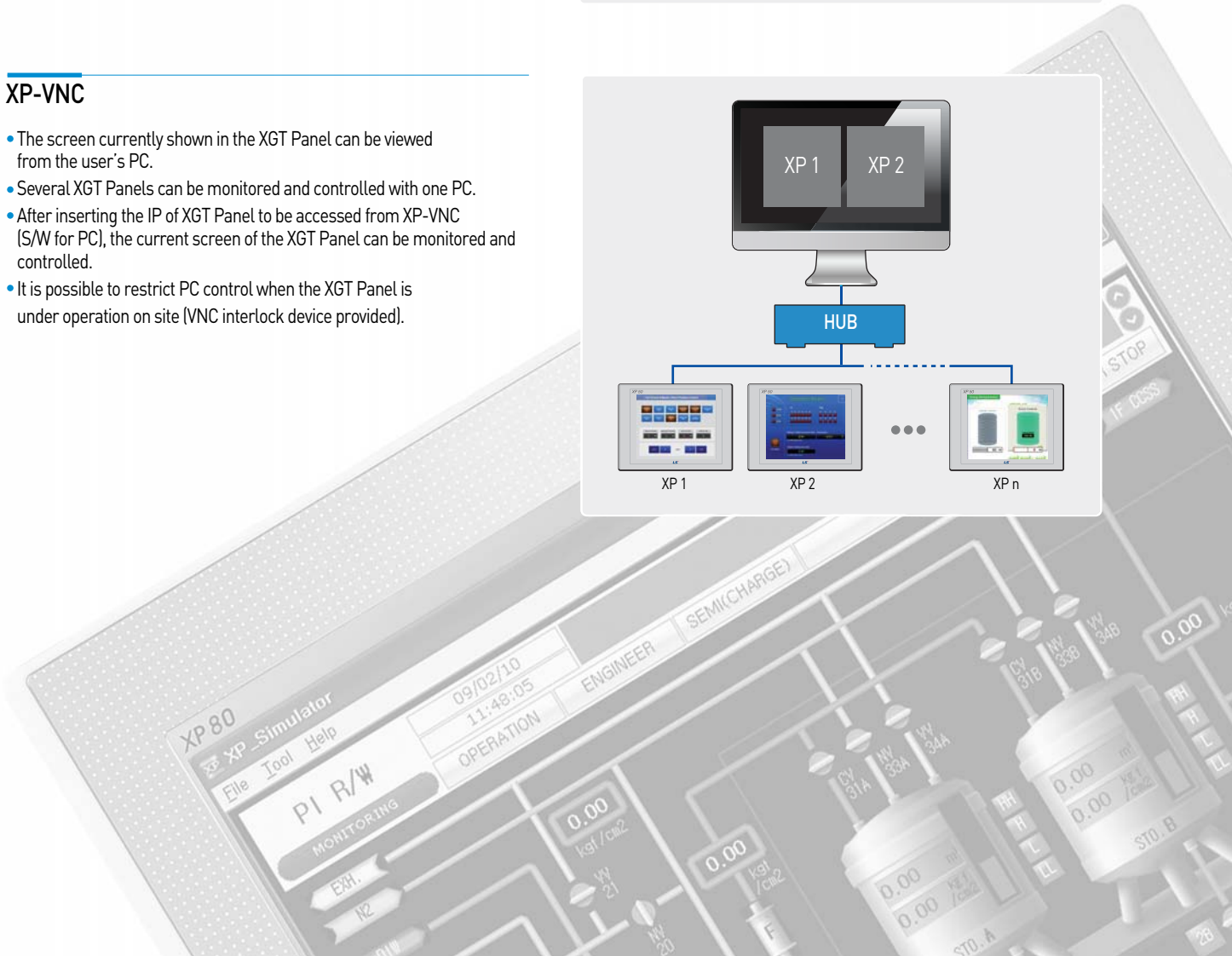
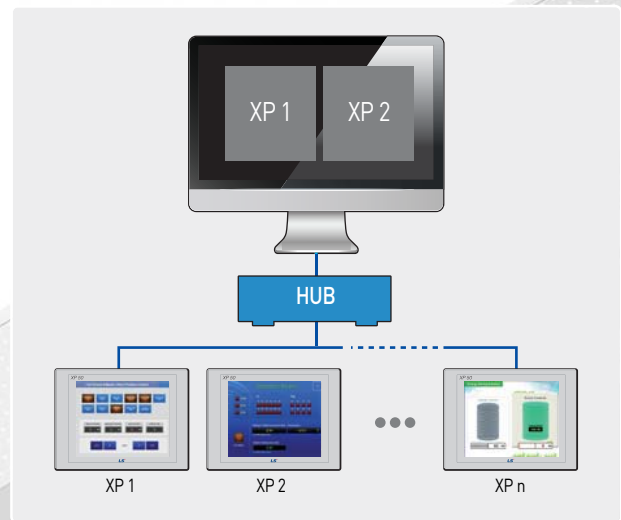



Feature

System Block Diagram

1 : 1 Serial/Ethernet Communication

One controller to one XGT Panel

- ※ In case of the 1:1 Ethernet communication, a cross cable should be used.

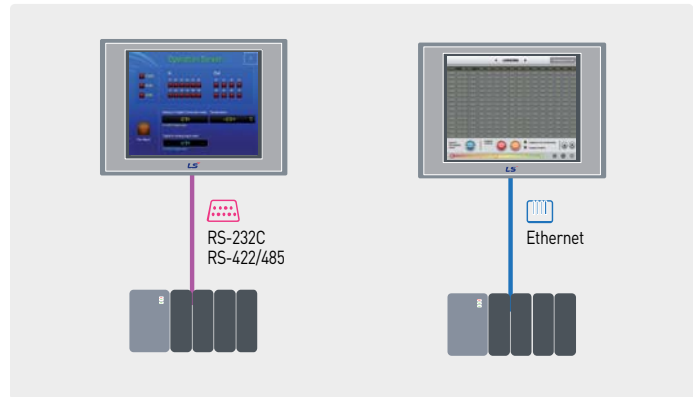

N : 1 Serial Communication

One controller to multiple XGT Panels (serial)

- ※ Up to 16 XGT Panels can be connected, but the speed for screen refreshing varies according to the number of panels.
- ※ Connection available only to specific controllers (limited to PLCs)

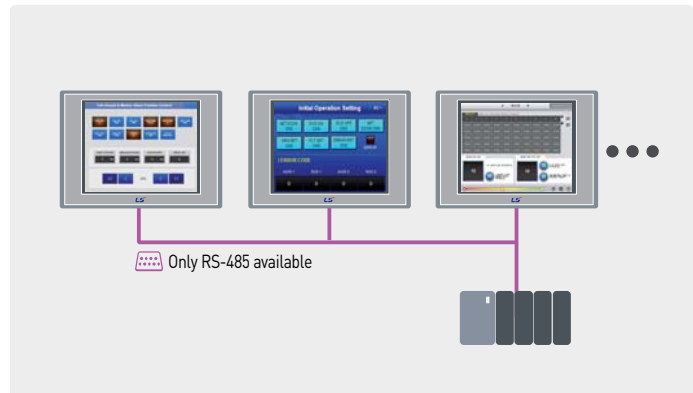

Simultaneous connection with multiple controllers

4 kinds of controllers to one XGT Panel

- ※ Without the RS-422/485 and RS-232C, up to 4 controllers can be connected using only Ethernet.
- ※ When it comes to iXP, up to 16 controllers can be connected.

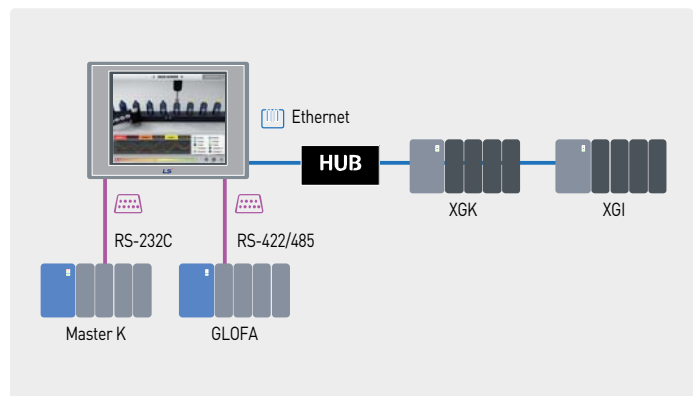

1 : N Serial Communication (Multi Drop)

Multiple controllers to one XGT Panel

- ※ When 1:N communication is applied, the same types of controllers should be used.

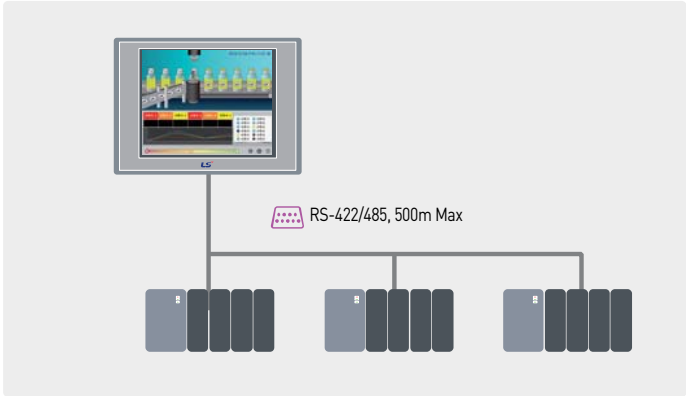

N:1 Ethernet Communication

One controller to multiple XGT Panels (Ethernet)

- ※ According to the controller type, the number of XGT Panels connected may vary.

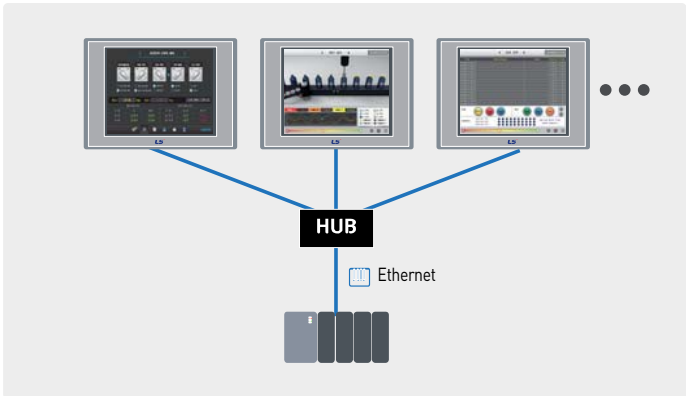

N:M Ethernet Communication

Multiple controllers to multiple XGT Panels

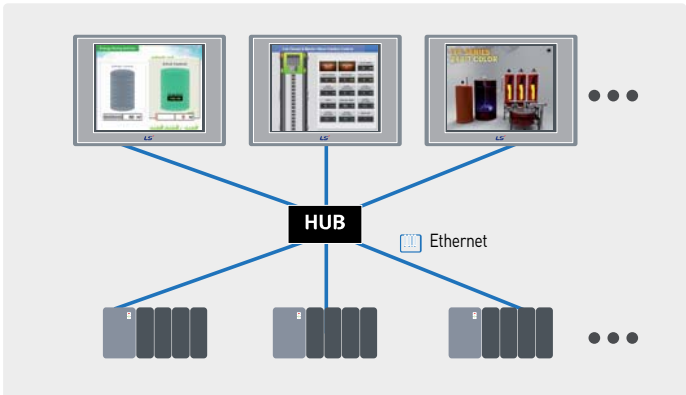

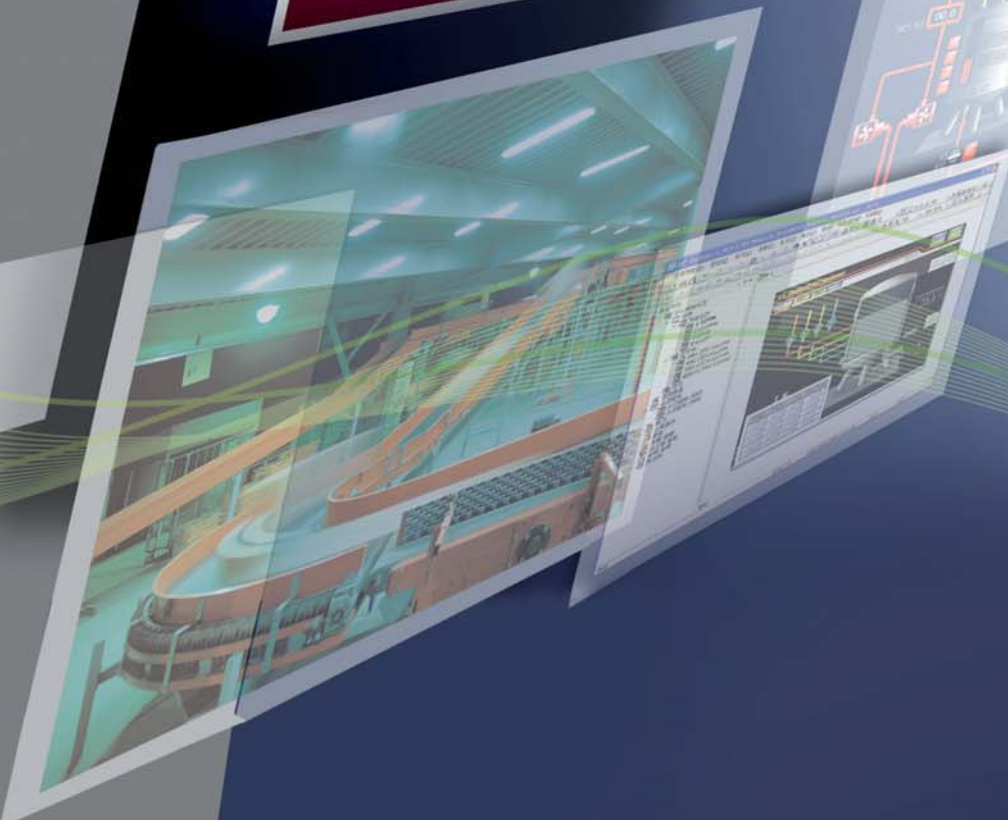

Our Solution

We are leaping as a global leader beyond the top enterprise in Korea in the field of automation solutions.

The LSIS HMI solutions incorporate the core H/W and S/W technologies and services, which are optimized for client's environments at various industrial sites, ranging from unit machines to massive process control.

iXP Series

High-resolution and performance

- 1GHz high-performing CPU & quick screen refreshing speed
- 16,777,216. TFT color (24bit) support & high-luminance/resolution LCD
- Mass internal memory (User memory: 128MB, Data backup: 1MB)

User-oriented simple environment

- Various storage interfaces (USB/SD)
- Movement detection (presence sensor) system (within 1m)



Dimensions

[Unit: mm]

iXP50

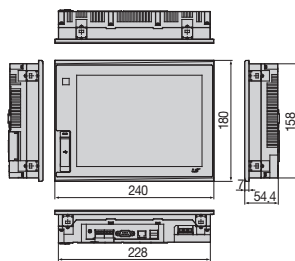

iXP70

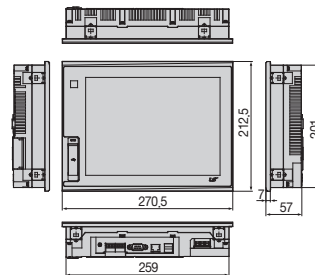

iXP80

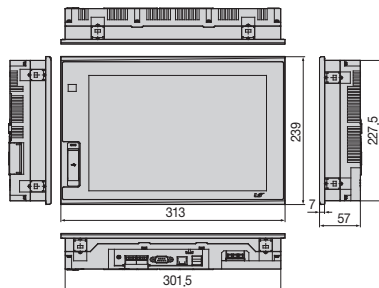

iXP90

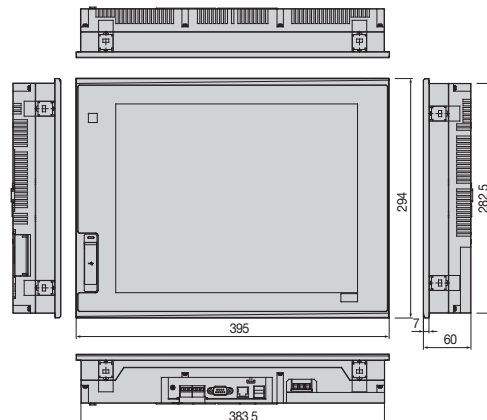

General Information

Item	Description	Standard	
Ambient Temperature	0°C~+50°C		
Storage Temperature	-20°C~+60°C		
Ambient Humidity	10~85%RH, without dew condensation		
Storage Humidity	10~85%RH, without dew condensation		
Vibration resistance	Occasional vibration		
	Frequency	Acceleration	Amplitude
	5 ≤ f < 9Hz	-	3.5mm
	9 ≤ f ≤ 150Hz	9.8%	-
	Continuous vibration		10 times each direction (X, Y and Z)
	Frequency	Acceleration	
5 ≤ f < 9Hz	-	1.75mm	
	9 ≤ f ≤ 150Hz	4.9%	-
Shock resistance	Maximum shock acceleration: 147% (15g) * Authorization time: 11ms * Pulse waveform: Half-sine wave (3 times each of X, Y and Z) *		IEC 61131-2
Vibration resistance	Square wave impulse noise	DC: ±800V	LSIS Standards
	Electrostatic discharge	±4kV (Contact discharge)	IEC 61131-2, IEC 61000-4-2
	Radiated electromagnetic field noise	80 ~ 100MHz, 10V/m	IEC 61131-2, IEC 61000-4-3
	Fast transient/Burst noise	Power Module: 2 kV, Communication Interface: 1kV	IEC 61131-2, IEC 61000-4-4
Operating ambience	Free from corrosive gas and excessive dust		
Altitude	2,000m (6,562ft) or below		
Pollution degree	2 or under		
Cooling method	Natural air-cooling		

Specifications

Item	iXP50-TTA/DC	iXP70-TTA/DC/AC	iXP80-TTA/DC/AC	iXP90-TTA/DC/AC
Display type	TFT LCD			
Screen size	21.3cm [8.4"]	26.4cm [10.4"]	30.7cm [12.1"]	38.1cm [15"]
Display Resolution	800 × 600 pixel (SVGA)	800 × 600 pixel (SVGA)	800 × 600 pixel (SVGA)	1,024 × 768 pixel (SVGA)
Color indication	16-bit and 24-bit Color (default: 16-bit Color)			
Indication degree	Left/Right: 80 deg. Up: 80 deg. Down: 60 deg.	Left/Right: 80 deg. Up: 60 deg. Down: 80 deg.		
Backlight	LED Type			
Backlight duration	70,000 hours	60,000 hours		
Brightness	500 cd/m ²	700 cd/m ²	550 cd/m ²	800 cd/m ²
Touch panel	4-Line type, analog			
Sound Output	Magnetic buzzer (85dB)			
Audio Output	1 channel, stereo audio output			
Process	ARM Cortex-A8 Core (32bit RISC), 1GHz			
Memory	Flash	512MB (display 128MB)	1GB (display 128MB)	
	Operating RAM	256MB	512MB	
	Backup RAM	1MB		
Backup data	Date/Hour data, Logging/Alarm/Recipe data and nonvolatile device			
Battery duration	Approx. 3 years (Operating ambient temperature of 25°...)			
Ethernet	1 channel, IEEE802.1a, 10Base-T/100Base-TX			
USB Host	3 channels, USB 2.0 host (mouse, keyboard, printer and USB memory driver is available)			
	1 channel, USB 2.0 slave (for download and upload project file)			
RS-232C	1 channel			
RS-422/485	1 channel, RS-422/485 mode			
SD Card	1 Slot (SDHC)			
Human sensor	-	Detection range: side 1-1.5m, front 40-50cm Angle: high/low 100°, left/right 140° (detecting 5-20 micron infrared light)		
Audio output	LINE-OUT 1 channel			
Expansion module	For communication and I/O option module (available later)			
VM module	-	4 channels video input (available later)		
Multi-language	Up to 8 language simultaneously			
Animation	GIF format is available			
Recipe	available			
Data logging	available			
Script executor	available			
Certifications	CE, UL(cUL), KC			
Protection standard	IP65			
Dimension (mm)	240.5 × 180.0 × 54.4	270.5 × 212.5 × 60.0	313.0 × 239.0 × 56.0	395.0 × 294.0 × 60.0
Panel cut (mm)	228.5 × 158.5	259.0 × 201.0	301.5 × 227.5	383.5 × 282.5
Rated voltage	DC24V		DC12/24V (AC 100-240V)	
Power consumption (W)	36	42	42	42
Weight (Kg)	1.9	2.2	2.4	3.9

XP Series

- 65,536 TFT color
- 4/10/20MB User memory, 128/512KB Backup memory
- Ethernet & serial communications support
- USB Host function to be used in various PC devices
- Up to 8 languages at a time and a batch-change of languages
- Offline simulations
(Link to the XG5000 simulator)



Dimensions

[Unit: mm]

XP30-BTE / TTE

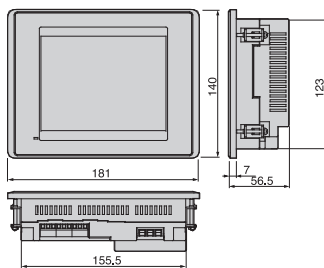

XP30-BTA / TTA

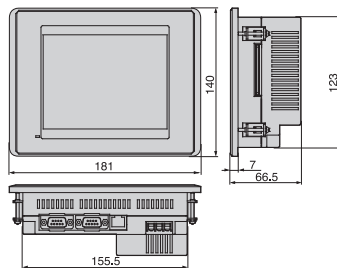

XP50-TTA

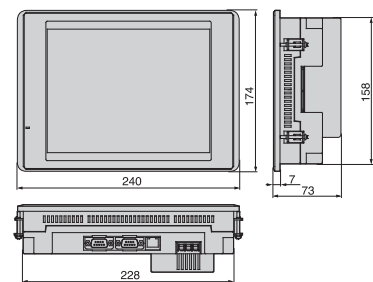

XP70-TTA / XP80-TTA

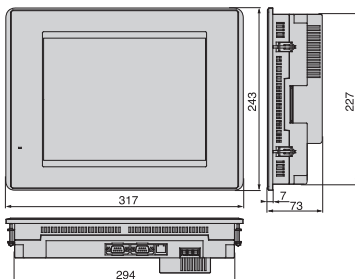

XP90-TTA

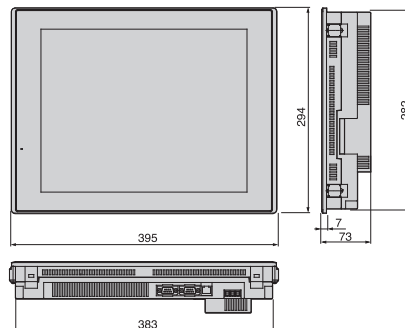

General information

No.	Item	Description	Standard		
1	Ambient temperature	0°C~+50°C			
2	Storage temperature	-20°C~+60°C			
3	Ambient humidity	10~85%RH, without dew condensation			
4	Storage humidity	10~85%RH, without dew condensation			
5	Vibration Resistance	-20°C~+60°C	Counts 10 times each direction (X, Y and Z) IEC 61131-2		
		Frequency		Acceleration	Amplitude
		5 ≤ f < 9Hz		-	3.5mm
		9 ≤ f ≤ 150Hz		9.8%	-
		Continuous Vibration			
		Frequency		Acceleration	Amplitude
	5 ≤ f < 9Hz	-	1.75mm		
	9 ≤ f ≤ 150Hz	4.9%	-		
6	Shock Resistance	Maximum shock acceleration: 147% _g (15g) Authorization time: 11ms Pulse waveform: Half-sine wave pulse (3 times each of X,Y and Z)	IEC 61131-2		
7	Noise Resistance	Square wave impulse noise	AC: ±1,500V DC: ±1,000V LSIS Standards		
		Electrostatic discharge	Voltage: 6 kV (Contact discharge) IEC 61131-2, IEC 61000-4-2		
		Radiated electromagnetic field noise	27 ~ 500MHz, 10V/m IEC 61131-2, IEC 61000-4-3		
		Fast transient/Burst noise	Power module: 2 kV, Communication interface: 1kV IEC 61131-2, IEC 61000-4-4		
8	Operating ambience	Free from corrosive gas and excessive dust			
9	Altitude	2,000m (6,562ft) or below			
10	Pollution degree	2 or under			
11	Cooling method	Natural air-cooling			

Specifications

Model Type	XP30-BTE/DC	XP30-BTA/DC	XP30-TTE/DC	XP30-TTA/DC	XP50-TTA/DC	XP70-TTA/AC XP70-TTA/DC	XP80-TTA/AC XP80-TTA/DC	XP90-TTA/AC
	Mono			Color				
Display Element	Mono Blue LCD			TFT Color LCD				
Screen Size	14cm [5.7"]			21cm [8.4"]	26cm [10.4"]	31cm [12.1"]	38cm [15"]	
Resolution	320×240			640×480		800×600	1024×768	
Color	8-column Gray Scale		256 colors	65,536 colors				
Backlight	LED mode		CCFL(LCD single body), Auto On/Off	CCFL(can be replaced), Auto On/Off				
	50,000 hours		60,000 hours	50,000 hours		60,000 hours		
Contrast	Adjustable		Fixed					
Luminance	230cd/m ²		400cd/m ²	480cd/m ²	430cd/m ²	400cd/m ²	450cd/m ²	
Viewing Angle	Up/Down(Degree)	20/40	80/80	70/50	50/60	45/65	45/75	60/50
	Left/Right(Degree)	45/45	80/80	70/70	65/65	65/65	65/65	75/75
Touch Panel	4-wire system, analogue			8-wire system, analogue				
Movement LED	Green: Normal RUN (Monitoring & drawing data download) Red: Error (Communication error & drawing data error)							
Memory	Screen Data	4MB	10MB	4MB	10MB			20MB
	Backup Data	128KB	512KB	128KB	512KB(saving logging/alarm data)			
Ethernet	-		1ch, IEEE802.3, 10/100Base-T	1ch, IEEE802.3, 10/100Base-T				
USB Interface	USB Host X 1	USB Host X 2	USB Host X 1	USB Host X 2				
Serial	RS-232C	2ch[1 port for PC communication]						
	RS-422/485	1ch, 422/485 optional mode						
CF Card Interface	-	CF card (TAPE-1)*1	-	CF card (TAPE-1)×1				
AUX Interface	-		Optional	Optional				
Certification	CE, UL, KCC							
Protection	IP65 (Front Water Proof Structure)							
Size(W×H×D)mm	181 x 140 x 56.5	181 x 140 x 66.5	181 x 140 x 56.5	181 x 140 x 66.5	240 x 174 x 73	317 x 243 x 73		395 x 294 x 73
Panel Cut (W×H)mm	155.5 x 123			228 x 158	294 x 227		383 x 282	
Weight (kg)	0.62	0.75	0.62	0.75	1.4	2.2	2.4	3.9
Power	Rated Voltage	DC 24V			AC100~220V, DC 24V			AC100~220V
	Permitted Voltage	AC	-					
		DC	MIN 19.2 VDC, MAX 28.8 VDC					
	Power Consumption (W)	AC	-			37	40	46
DC		5	8.5	5	8.5	20	27	30

XP40 (7" Wide Type)

- 17.7cm (7") TFT LCD-applied wide type
- LED Backlight adopted for enhanced contrast ratio and low-power
- PLC Ladder monitoring function: Only XGK/XBC supports*
- Web Server* / Data Server* / Path-Through Function*
- Remote Viewer Function*
- CE, KC, UL/cUL certifications
- Screen editor : XP-Builder
- *Functions that support only the TTA model



Dimensions

[Unit: mm]

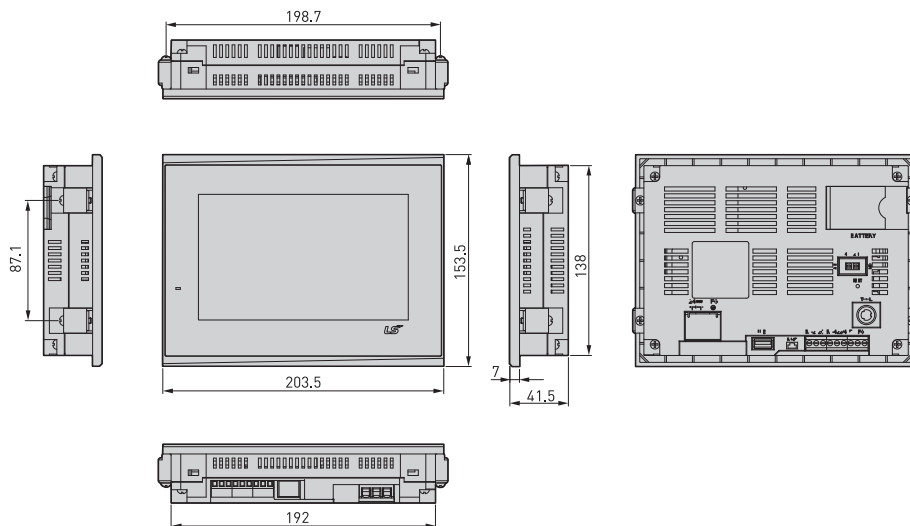

General Information

Item	Description	Standard	
Ambient temperature	0°C~+50°C		
Storage temperature	-20°C~+60°C		
Ambient humidity	10~85%RH, without dew condensation		
Storage humidity	10~85%RH, without dew condensation		
Vibration resistance	Occasional Vibration		
	Frequency	Acceleration Amplitude	
	5 ≤ f < 9Hz	- 3.5mm	
	9 ≤ f ≤ 150Hz	9.8% -	
	Continuous Vibration		
	Frequency	Acceleration Amplitude	
	5 ≤ f < 9Hz	- 1.75mm	
	9 ≤ f ≤ 150Hz	4.9% -	
	Counts	10 times each direction (X, Y and Z)	
		IEC 61131-2	
Shock resistance	Maximum shock acceleration: 147%(15g) Authorization time: 11ms Pulse waveform: Half-sine wave pulse (3 times each of X,Y and Z)	IEC 61131-2	
Noise resistance	Square wave impulse noise	DC: ±800V	LSIS Standards
	Electrostatic discharge	±4kV (Contact discharge)	IEC 61131-2, IEC 61000-4-2
	Radiated electromagnetic field noise	80 ~ 100MHz, 10V/m	IEC 61131-2, IEC 61000-4-3
	Fast transient/Burst noise	Power module: 2 kV, Communication interface: 1kV	IEC 61131-2, IEC 61000-4-4
Operating ambience	Free from corrosive gas and excessive dust		
Altitude	2,000m (6,562ft) or below		
Pollution degree	2 or under		
Cooling method	Natural air-cooling		

Specifications

Item	XP40-TTE/DC	XP40-TTA/DC
Display Type	TFT color LCD	
Display Size	17.7cm (7inch)	
Resolution	800 x 480 pixels	
Color	256 colors	65,536 colors
Display Angle	Left/Right: 65 deg. Up: 50 deg. Down: 60 deg.	
Backlight	LED mode (can be replaced)	
Backlight Capacity	30,000 hr. or more	
Brightness	280 cd/m ²	
Touch Panel	Analogue resistive	
Sound	Magnetic buzzer (87dB)	
Processor	ARM920T (32bit RISC), 200MHz	
Graphic Accelerator	Hardware accelerator	
Memory	Flash	16MB 32MB
	Operation RAM	32MB 64MB
	Backup RAM	128KB 512KB
Backup Type	Date/Time data, Logging/Alarm/Recipe data, non-volatile device	
Batter Capacity	Around 3 years (Upon operation at 25°C)	
USB Host	1 channel, USB 2.0 (supports printer and USB memory driver)	
RS-232C	Terminal block type	
RS-422/485		
Ethernet	-	1 channel, IEEE802.3, 10Base-T / 100Base-TX
Certification	CE, UL(cUL), KC	
IP	IP65	
Size (mm)	203.5 × 153.5 × 41.5	
Panel Cut (mm)	192 × 138	
Power	DC24V	
Power Consumption (W)	4.5 or less	5.0 or less
Weight (kg)	0.8	0.81



List of Communication Drivers

Manufacturer	Controller
LSIS	XGK (Link)
	XGK (CPU)
	XGK (Ethernet)
	XGK (Ethernet/IP)
	XGI (Link)
	XGI (CPU)
	XGI (Ethernet)
	XGI (Ethernet/IP)
	XGR (Link)
	XGR (CPU)
	XGR (Ethernet)
	XGR (Ethernet/IP)
	XEC (Link)
	XEC (CPU)
	XEC (Ethernet)
	XEC (Ethernet/IP)
	XGB (Link)
	XGB (CPU)
	XGB (Ethernet)
	XGB (Ethernet/IP)
	GLOFA-GM (Link)
	GLOFA-GM (CPU)
	GLOFA-GM (Ethernet)
	MASTER-K (80,120,200,300,1000)S (Link)
	MASTER-K (80,120,200,300,1000)S (CPU)
	MASTER-K (200,300,1000)S (Ethernet)
XGT Servo	
Inverter (LSBus)	
Inverter (MODBUS)	
User Defined Communication (Master - Serial/Ethernet)	
User Defined Communication (Slave - Ethernet)	
Mitsubishi	MELSEC-A (Link)
	MELSEC-A (CPU)
	MELSEC-FX (Link)
	MELSEC-FX (CPU)
	MELSEC-FX (Ethernet)
	MELSEC-Q (CPU) , *U Type excluded
	MELSEC-QnA,Q (Link)
	MELSEC-QnA,Q (Ethernet)
	MELSEC-QnU CPU Built-in Ethernet
	MELSERVO-J2
	MELSERVO-J3
	C/CV Host Link
OMRON	CS/CJ Series Host Link
	CS/CJ Series (Ethernet)
	CJ1/CJ2 (Ethernet/IP)
	SLC500 Series (DF1)
Rockwell	ControlLogix/CompactLogix Series (DF1)
	MicroLogix Series (DF1)
	ControlLogix/CompactLogix Series Native (Ethernet/IP)
	Ethernet/IP MicroLogix Series (Ethernet/IP)

Manufacturer	Controller
Schneider Electric Industries	MODBUS RTU/ASCII Master
	MODBUS TCP/IP Master
	MODBUS RTU/ASCII Slave
	MODBUS TCP/IP Slave
RS Automation	N/NX Series CCU
	NX Series CCU+
Siemens	SIMATIC S7 MPI (PC Adaptor)
	SIMATIC S7 PPI
	SIMATIC S7 3964(R)/RK512
	SIMATIC S7 (Ethernet)
	LOGO (Ethernet)
KDT Systems	SIMATIC S7 1200 (Ethernet)
	BP Series Loader
	CP Series Loader
	XP Series Loader
LS Mecapion	KDT CIMON Serial (Link)
	VS/VP Servo Drive
GE Fanuc	MXQ Series
	90-30/70 SNP
Panasonic	90-30/70 SNP-X
	MINAS Servo
Hyundai Elevator	FP Series (Link)
	SKY-RAV (Link)
Daewon	SKY-RAV (Ethernet)
Parker	GSI Dedicated Controller
Digital	Hi-Drive
CANopen Slave	Memory Link
Profibus DP Slave	CANopen Slave
Delta	PROFIBUS DP Slave
Fuji	DVP Series
	MICREX-SX Series (Link)
Hanyoung	MICREX-SX Series (Ethernet)
CAS	Temperature Controller
HIGEN	Weight Indicator
SEW EURODRIVE	Servo
Lenze	MOVIDRIVE Serial
YOKOKAWA	Lecom A/B
	FA-M3 Series
BACnet	FA-M3 Series (Ethernet)
Control Techniques	IP Master
KOYO	CT Modbus RTU
KTURBO	DirectNet Serial
BYD Auto	Turbo Blower MT508
YASKAWA	BYD Dedicated Controller
	MEMOBUS RTU Master
HITACHI	MP2000 Series (Ethernet)
	H Series (Link)
KEYENCE	H Series (Ethernet)
	KV-700/1000/3000/5000/5500 Serial
DasaRobot	KV-700/1000/3000/5000/5500 (Ethernet)
	DASA iM-SIGMA Series

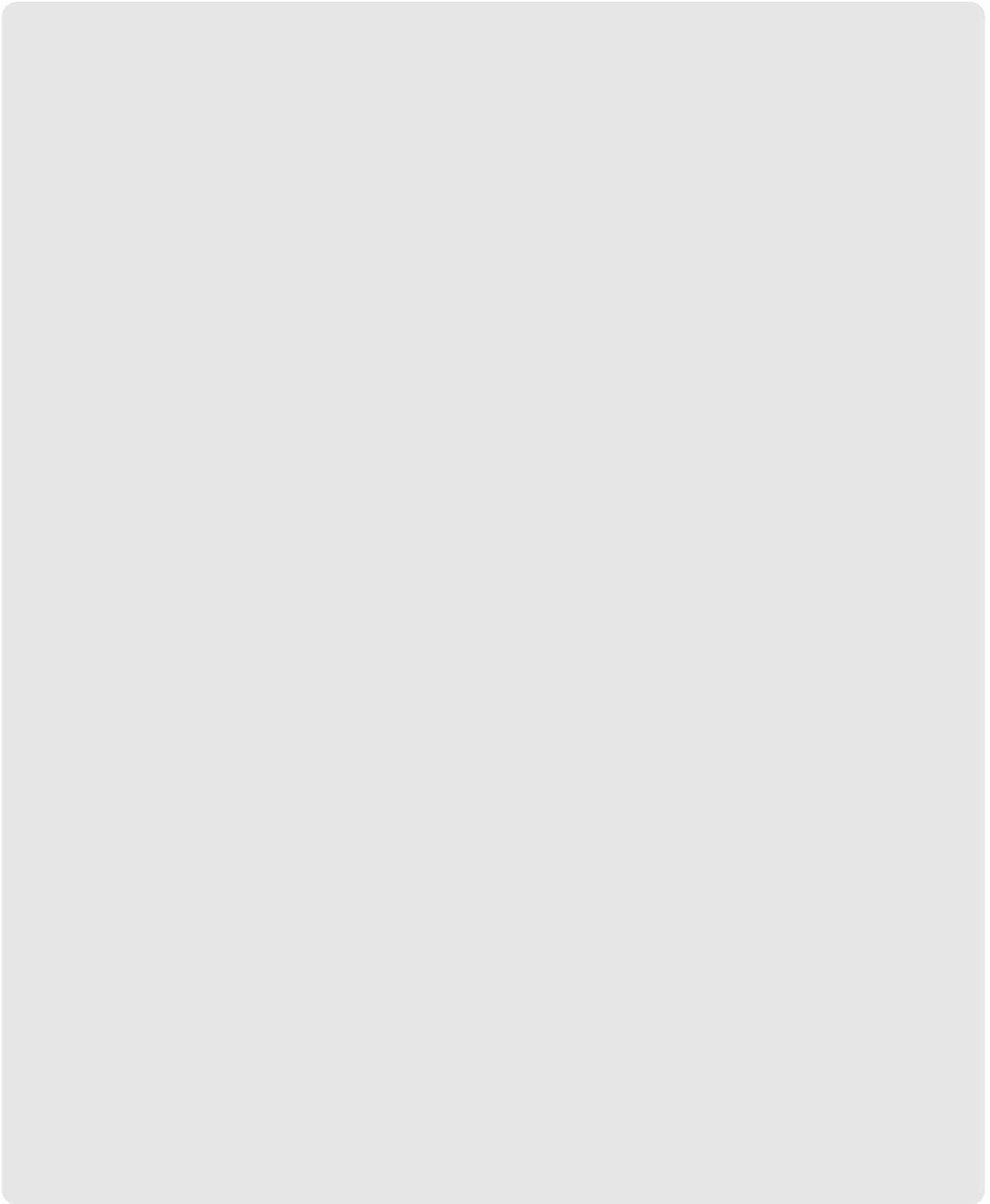

FUTURING SMART ENERGY



Safety Instructions

- For your safety, please read user's manual thoroughly before operating.
- Contact the nearest authorized service facility for examination, repair, or adjustment.
- Please contact qualified service technician when you need maintenance.
Do not disassemble or repair by yourself !
- Any maintenance and inspection shall be performed by the personnel having expertise concerned.

LSIS Co., Ltd.

©2006. LSIS Co., Ltd. All Rights Reserved.

HEAD OFFICE

LS Tower, 127, LS-ro, Dongan-gu, Anyang-si, Gyeonggi-Do, 431-848, Korea

■ Southeast Asia	+82-2-2034-4888	cshwang@lsis.com (Charles Hwang)
■ Europe	+82-2-2034-4676	sukyong@lsis.com (Brian Choi)
■ Turkey/Israel/CIS	+82-2-2034-4879	dkimcd@lsis.com (Daniel Kim)
■ Oceania	+82-2-2034-4394	kacho@lsis.com (Kendra Cho)
■ North/Latin America	+82-2-2034-4286	hkchung@lsis.com (Hank Raul Chung)
■ Southwest Asia/Africa	+82-2-2034-4467	myleed@lsis.com (Henry Lee)
■ Middle East	+971-4-886-5360	khchoi1@lsis.com (Lambert Choi)

Overseas Subsidiaries

- **LSIS USA Inc., Chicago, U.S.A.**
2000 Millbrook Drive, Lincolnshire, Chicago, IL 60069, United States
Tel : 847-941-8240 Fax : 847-941-8259
- **LSIS(ME) FZE Dubai, U.A.E.**
LOB 19-205, JAFZA View Tower, Jebel Ali Free Zone, Dubai, United Arab Emirates
Tel : 971-4-886-5360 Fax : 971-4-886-5361
- **LSIS(Shanghai) Co., Ltd., Shanghai, China**
32nd Floor, International Corporate City, No.3000 NorthZhongshan Road, Putuo District, Shanghai, China, 200063
Tel : 86-21-5237-9977-8609 Fax : 86-21-5237-7189
- **LSIS(Dalian) Co., Ltd., Dalian, China**
No. 15, Liaohexi 3-Road, Economic and Technical Development Zone, Dalian 116600, China
Tel : 86-411-8730-7510 Fax : 86-411-8730-7560
- **LSIS(Wuxi) Co., Ltd., Wuxi, China**
No. 1, Lexing Road, Wuxi National High & New Tech Industrial Development Area, Wuxi214028, Jiangsu, P.T.China
Tel : 86-510-8534-6666-8005 Fax : 86-510-8534-4078
- **LS Hukai Electric(Hubei) Co., Ltd., Hubei, China**
No. 100, Tanjiahe Road, Dianjun District, Yichang City, Hubei Province, 443004, China
Tel : 86-717-667-7339 Fax : 86-717-667-7559
- **LS-VINA Industrial Systems Co., Ltd., Hanoi, Vietnam**
Nguyen Khe, Dong Anh, Hanoi, Vietnam
Tel : 84-4-6275-8055 Fax : 84-4-3882-0220
- **LSIS Europe B.V., Netherlands**
1st. Floor, Tupolevlaan 48, 1119NZ, Schiphol-Rijk, The Netherlands
Tel : 31-20-654-1420 Fax : 31-20-654-1429
- **LSIS Japan Co., Ltd., Tokyo, Japan**
Tokyo Club Building 13F, 2-6, Kasumigaseki 3-chome, Chiyoda-ku, Tokyo, 100-0013
Tel : 81-3-6268-8241 Fax : 81-3-6268-8240

Overseas Branches

- **LSIS Detroit Office, U.S.A.**
5700 Crooks Rd, Suite 211, Troy, MI 48098, USA
Tel : 1-248-792-2637-8 Fax : 1-248-792-2642
- **LSIS Shanghai Office, China**
32nd Floor, International Corporate City, No.3000 NorthZhongshan Road, Putuo District, Shanghai, China, 200063
Tel : 86-21-5237-9977 Fax : 86-21-5237-7189
- **LSIS Beijing Office, China**
Room 2306, Building B Landgent Center, No.24 Middle Road, East 3rd Ring Road, Chaoyang District, Beijing, P.R. China
Tel : 86-10-5761-3127 Fax : 86-10-5761-3128
- **LSIS Guangzhou Office, China**
Room 1818-1820, Xinyuan Building, NO.898 Tianhe North Road, Tianhe District, Guangzhou, P.R. China
Tel : 86-20-8326-6784 Fax : 86-20-8326-6287
- **LSIS Chengdu Office, China**
Room 1710, 17/F Huamin Empire Plaza, NO.1 Fuxin Road, Chengdu, P.R. China
Tel : 86-28-8670-3200 Fax : 86-28-8670-3203
- **LSIS Qingdao Office, China**
Room 2001, Galaxy Building, 29 ShanDong Road, ShiNan District, QingDao, ShanDong, P.R. China
Tel : 86-532-8501-6058 Fax : 86-532-8501-6057
- **LSIS ShenYang Office, China**
Room 803, Hongyuan Building, 52 South Nanjing Road, Heping District, Shenyang, P.R. China
Tel : 86-24-2321-9050 Fax : 86-24-2321-9050
- **LSIS Jinan Office, China**
Room 317, Chuangzhan Center, No. 201, Shanda Road, Lixia District, Jinan, Shandong, P. R. China
Tel : 86-531-8699-7826 Fax : 86-531-8697-7628
- **LSIS Co., Ltd. Rep. Office, Vietnam**
Gema Dept Tower 18F, 6 Le Thanh Ton, District 1, HCM, Vietnam
Tel : 84-8-3823-7890 Fax : -
- **LSIS Co., Ltd. Tokyo Office, Japan**
Tokyo Club Building 13F, 2-6, Kasumigaseki 3-chome, Chiyoda-ku, Tokyo, 100-0013
Tel : 81-3-6268-8241 Fax : 81-3-6268-8240
- **LSIS Co., Ltd. India Office, India**
109 First Floor, Park Central, Sector-30, Gurgaon- 122 002, Haryana, India
Tel : 91-1244-930-077 Fax : 91-1244-930-066
- **LSIS Moscow Office, Russia**
123610, Krasnopresnenskaya, nab., 12, building 1, office 41005, Moscow, Russia
Tel : 7-495-258-1466/1467 Fax : 7-495-258-1466/1467
- **LSIS U.K. Office, United Kingdom**
G17 Bedford I-Lab, Stannard Way, Priory Business Park, Bedford, MK44 3RZ, U.K.
Tel : 44-012-3483-4774 Fax : 44-012-3483-4775

Specifications in this catalog are subject to change without notice due to continuous product development and improvement.